



***PANTHER***  
**FACING LATHE MACHINE**  
**INSTRUCTION & SPARE PARTS**  
**MANUAL**

**MODEL :- PFL-17**

**MACHINE No. :-**

**GUJARAT LATHE MFG. CO. PVT. LTD.**



# **PANTHER**

**ALL GEARED PRECISION LATHE MACHINE  
MODEL – PFL / 17**

**MANUFACTURED BY:**

**GUJARAT LATHE MFG. CO. PVT. LTD.**

**WORKS:**

NATIONAL HIGHWAY-8B,  
OPP. FIELD MARSHALL  
HIGH SCHOOL,  
SHAPAR-360024, DIST. RAJKOT  
PHONE:(02827) 252394  
FAX: (02827) 252357  
Email:[gujaratlathe@hotmail.com](mailto:gujaratlathe@hotmail.com)

**HEAD OFFICE:**

201-202, "KARMA STAMBH",  
LBS MARG, VIKHROLI (W),  
MUMBAI-400083  
PHONE: (022) 67242000  
FAX: (022) 25798809  
: (022) 67969652  
Email : [info@gujaratlathe.com](mailto:info@gujaratlathe.com)  
: [macspare@vsnl.com](mailto:macspare@vsnl.com)

**SALES OFFICE:**

**BARODA**

**STD:-** 0265  
**PHONE:-** 2641121/7551  
**FAX :-**2647551  
**E-mail :-** [barodaoffice@gujaratlathe.com](mailto:barodaoffice@gujaratlathe.com)

**BENGALURU**

080  
25587728  
25594143  
[bangaloreoffice@gujaratlathe.com](mailto:bangaloreoffice@gujaratlathe.com)

**CHENNAI**

044  
25221245/46  
25221245  
[chennaioffice@gujaratlathe.com](mailto:chennaioffice@gujaratlathe.com)



## **PREFACE**

This machine has been manufactured with a view to obtain the good working accuracy and it has been thoroughly tested for the better performance.

This accuracy of the machine can be achieved and maintained only if the instructions contained in this manual are strictly followed. The users of the machine are therefore, requested to get themselves acquainted with contents of the manual, before installation, operation and maintenance of the machine. It is suggested that a copy of this manual be made available to the operation and maintenance staff on the shop floor, who will be directly handling this machine.

As the machine and accessories are constantly being improved this manual may differ in detail with the machine supplied.

At the time of ordering the spares, please mention the component number as indicated in this manual and serial number of the machine which is stamped on right hand corner of the lathe machine bed.

**Please read Instruction Manual before starting the machine.**

For easy reference and understanding, this manual is divided into following five different sections.

Section 1 Introduction

Section 2 Installation

Section 3 Operation

Section 4 Settings, Maintenance and Trouble Shootings

Section 5 Assembly drawing and Spare-part list

**INDEX**

SR. NO	SECTION	DESCRIPTION		P.NO
1	<b>Introduction</b>	1.1	Machine specification	6
		1.2	Packing slip	7
		1.3	List of accessories	8
		1.3.1	Standard accessories (To be supplied with m/c.)	8
			Optional accessories	8
		1.4	Legend	12
2	<b>Installation</b>	2.1	Lifting of the machine	14
		2.2	Unpacking of the machine	15
		2.3	Foundation of the machine	15
		2.4	Leveling of the machine	17
		2.5	Electric diagram	18
		2.6	Electric connection	18
		2.7	Idle running of the machine	19
		2.8	Lubrication points	21
		2.9	Lubrication	23
		2.9.1	Lubrication through oil holes	24
			Lubrication through oil nipple	24
			Lubrication routine check	25
3	<b>Operation</b>	3.1	Safety	27
		3.2	Do, Do not ,Checks	28
		3.3	Head stock	29
		3.3.1	RPM chart	29
			Feed range chart	30
		3.4	Feed gear box	31
		3.5	Carriage	29
4	<b>Setting &amp; maintain</b>	4.1	Head stock	32
		4.1.1	Taper setting	32
			Spindle setting	32
			'V' Belts setting	32
		4.2	Lead screw	32



<b>SR. NO</b>	<b>SECTION</b>	<b>DESCRIPTION</b>		<b>P.NO</b>
		4.3	Carriage	33
		4.4	Compound slide and compound base	33
		4.5	Tool post	33
		4.6	Trouble shooting remedy	34
<b>5</b>	<b>Assembly drawings and part list</b>	5.1	Head stocks sub assembly	42
		5.2	Feed gear box sub assembly	48
		5.3	Carriage, gears and tool post assembly	53
		5.4	Safety door sub assembly	57
		5.5	Bed setting alignment sub assembly	60
		5.6	Hanging panel sub assembly	62

**Section -1****INTRODUCTION****1.1. Machine Specification**

<b>Type of bed</b>	<b>Gap bed</b>
Type of bed	Without Gap
Width of bed	500 mm
Height of center	850 mm
Swing over base	1700 mm
Swing over saddle	650 mm
No. of spindle speed	6
Spindle speed range	15 to 115 RPM
Spindle hollow	104 mm
Spindle nose detail	Bayonet size 11
Range of Longitudinal feeds	Step-less
Range of Transverse feeds	Step-less
Lead screw	32mm X 5mm L.H
Cross feed travel of slide carriage	850 mm
Longitudinal feed travel of tool slide	300 mm
Tool shank size	40 X 40 mm

<b><u>Types of bed</u></b>	<b>PFL-17</b>
Length of bed	1450 mm
Net weight	7000 kgs.
Motor	10 H.P.



**1.2 PACKING SLIP**

Machine Model :- PFL-17	Machine specification :-
Machine Sr. No. :-	Date :-

STANDARD ACCESSORIES			EXTRA ACCESSORIES		
1	Hardened guide ways	1 no.	1	Digital read out system(DRO)	no.
2	Center adaptor	1 no.	2	Telescopic guard for X & Z axis	no.
3	Dead center MT-5	1 no.			
4	Instruction manual	1 no.			
5	Tool post key	1 no.			
6	Oil can	1 no.			
7	Screw driver	1 no.			
8	Allen keys set	1 set			
9	Fixed spanner 12x13, 16x17, 18x19, 19x22, 24x26, 30x32	6nos.			
10	Main electric motor: Make :- _____ H.P. :- _____,RPM :- _____ Sr. No. :- _____	1no.			
11	V-Belt No. :-	5 nos.			
12	Feed Electric motor: Make :- _____ H.P. :- _____,RPM :- _____ Sr. No. :- _____	1 no.			
13	V-Belt No:- _____	2 no.			
14	Machine lamp	1 no.			
15	Face plate with 4 Nos.jaws block Dia.-1500mm	1no.			
16	Electrical control panel + key	1 no.			
17	Lubrication hand pump	1 no.			

Any other accessories:- Nil

Mode of packing :- \_\_\_\_\_

Name & Address: - \_\_\_\_\_

\_\_\_\_\_

Checked by:- \_\_\_\_\_

[NOTE: If any discrepancy is found with regard to the above accessories. It should be immediately notified to us along with machine Sr. No.]



### **1.3 List of Accessories:**

#### **1.3.1 Standard Accessories (To be supplied with machine)**

- Complete machine with electrical
- Electric motor with V-belt
- Face plate Ø1500mm with manual 4 jaw
- Machine lamp
- Front door
- Instruction manual
- Tool post key
- Oil can
- Screw driver
- Allen keys - 1 set
- Fixed spanner - 9 nos.
- Rear splash guard

#### **1.3.2 Optional Accessories (Retro fitting possible)**

- Digital read out system (DRO)
- Telescopic guard for X & Z axis





1.4 Legend

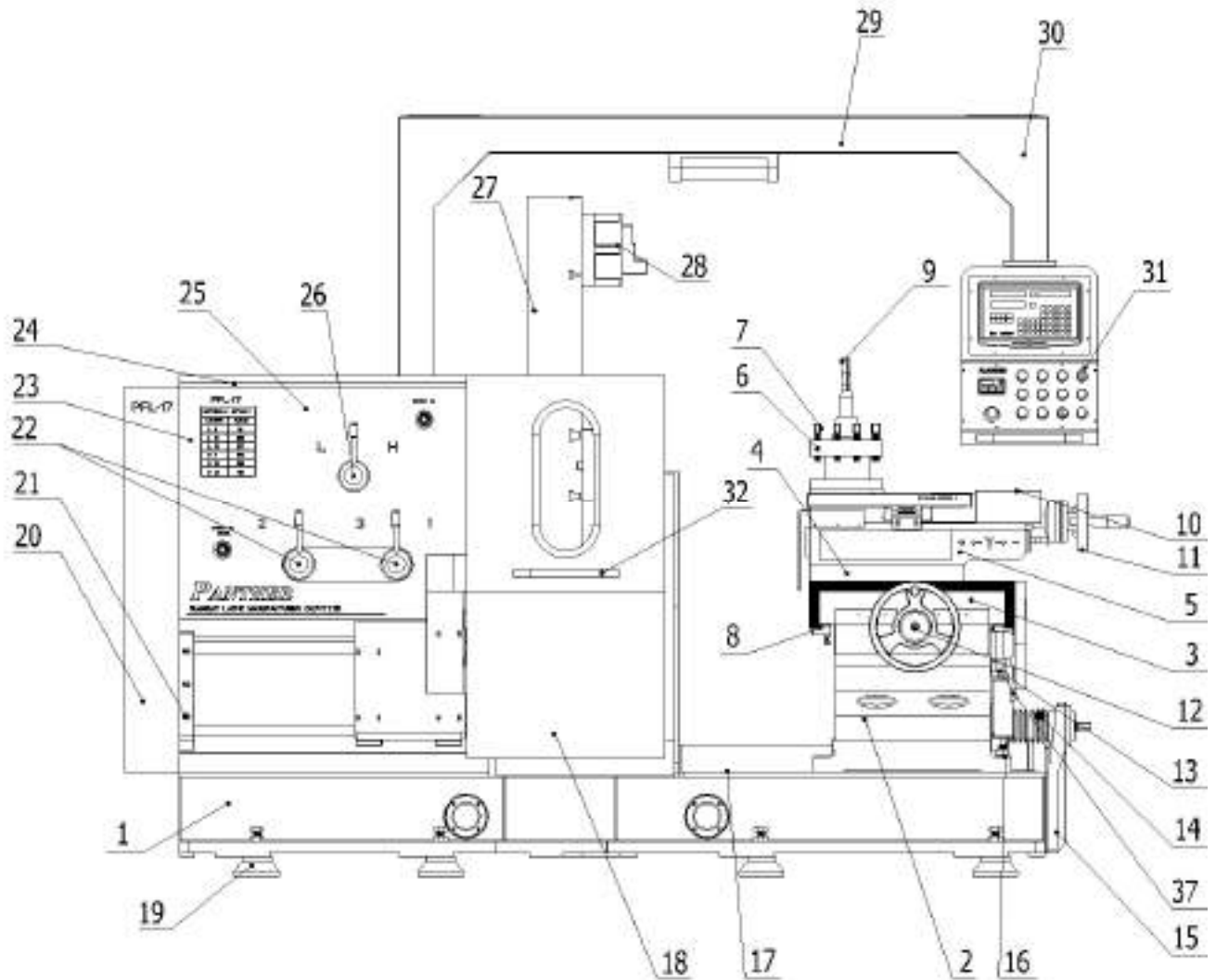

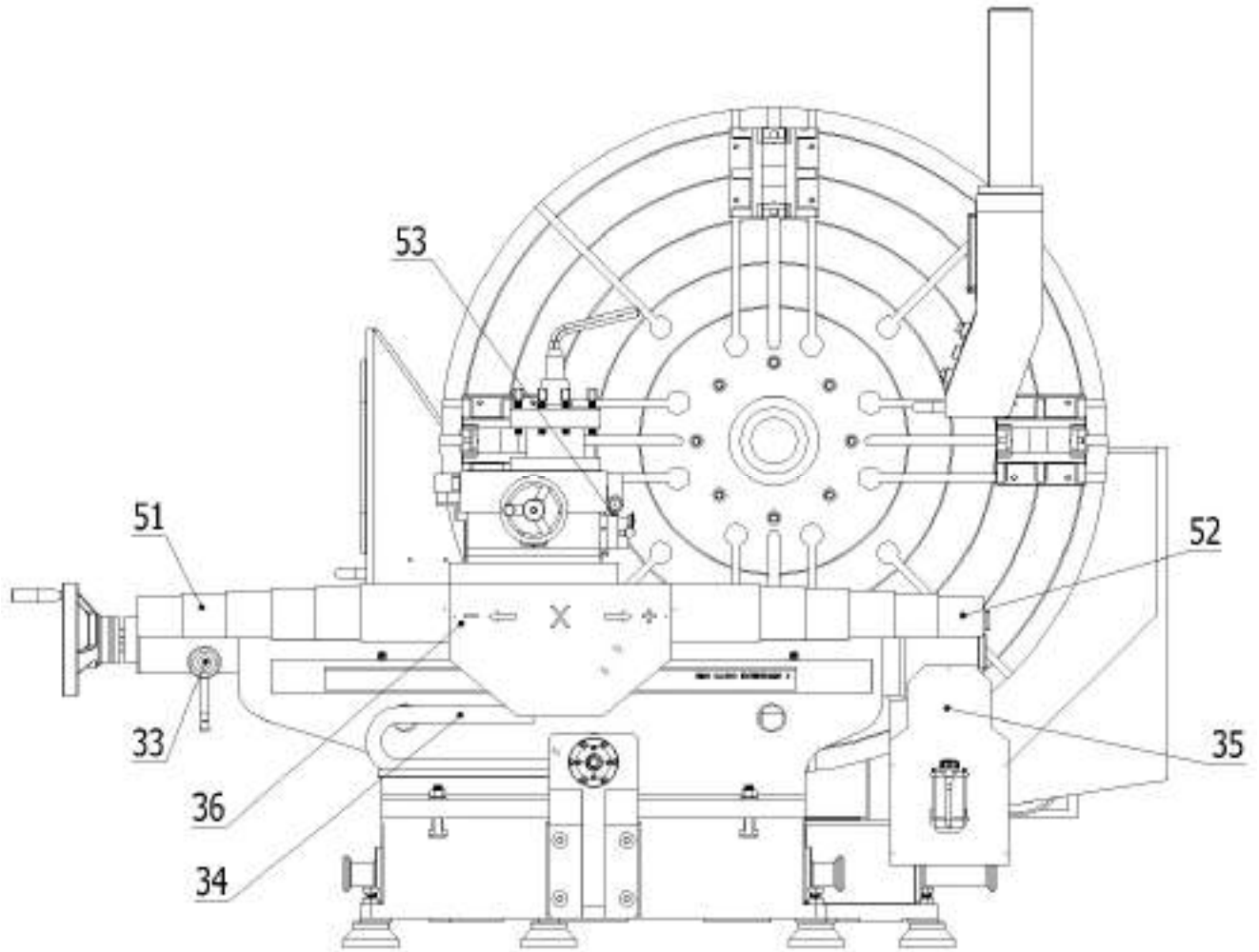

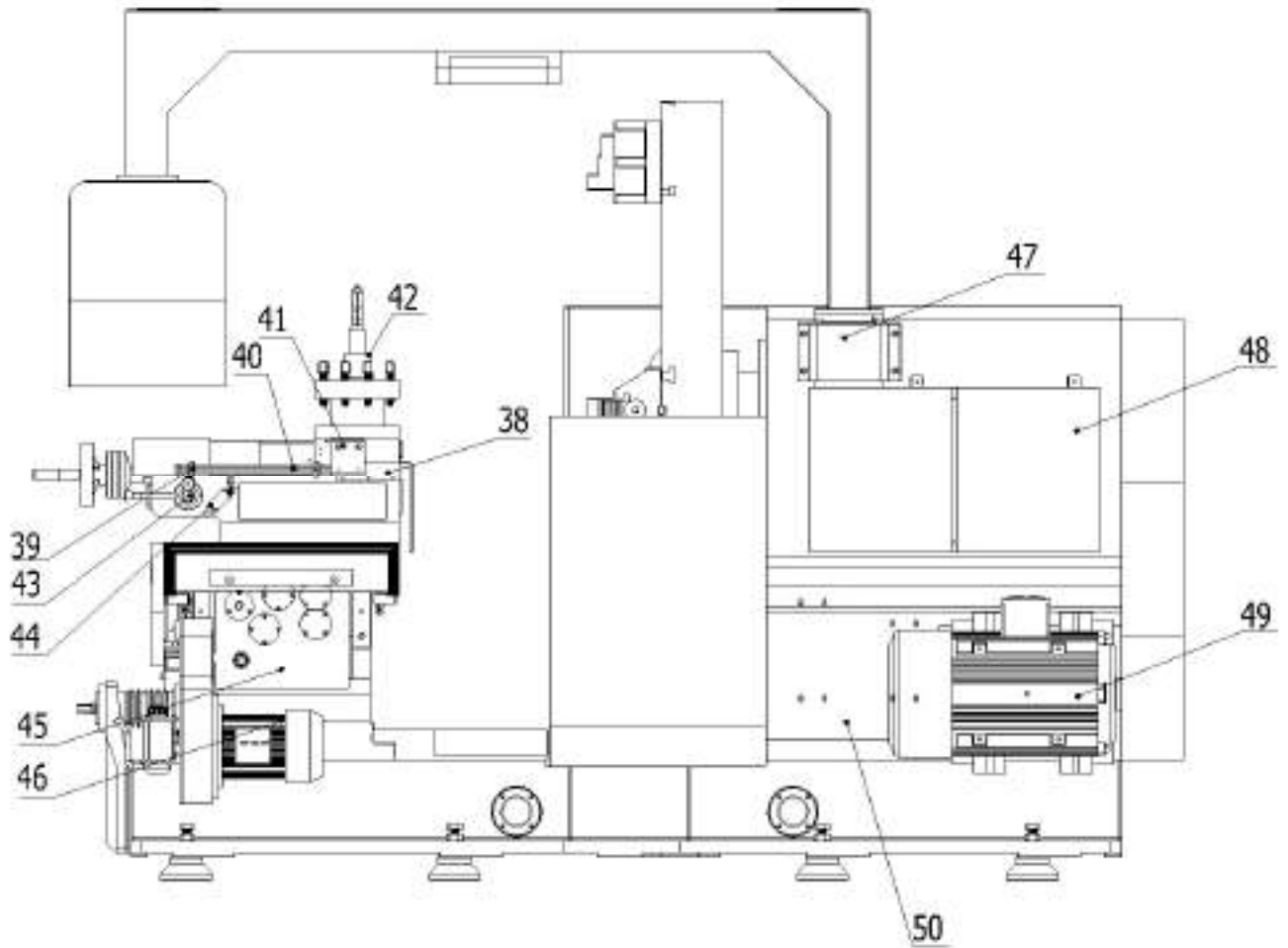



## 1.4Legend

- (01) Base
- (02) bed
- (03) Saddle assembly
- (04) Surface
- (05) Compound
- (06) Compound slide assembly
- (07) Tool post assembly
- (08) Keeper wedge
- (09) Tool clamping handle
- (10) Telescopic guard (for compound)
- (11) Compound hand wheel
- (12) Saddle hand wheel
- (13) Oil hand pump
- (14) Bed adjustment screw
- (15) Bed screw assembly
- (16) Bed bolt
- (17) Chip tray
- (18) Chuck guard assembly
- (19) Leveling pad
- (20) V-belt guard
- (21) Chuck guard cover pata assembly
- (22) Speed change lever
- (23) Head stock name plate
- (24) Head stock top cover
- (25) Head stock assembly
- (26) High-Low speed lever
- (27) Chuck
- (28) Chuck's jaws
- (29) Machine light
- (30) Hanging panel assembly
- (31) DRO screen
- (32) Door handle
- (33) Rapid & feed lever
- (34) Wire chain
- (35) Feed gear box cover
- (36) Saddle guard
- (37) Feed lever handle
- (38) Flexible apron cover support pad
- (39) Limit switch dog



- (40) Limit switch rod
- (41) Limit switch rod housing
- (42) Door guard slide bar
- (43) Compound feed lever
- (44) Limit switch
- (45) Feed gear box assembly
- (46) Electric motor (for feed box gear)
- (47) Hanging panel assembly
- (48) Electric panel board
- (49) Electric motor (for headstock)
- (50) Head-stock high piece
- (51) Telescopic guard left side
- (52) Telescopic guard right side
- (53) Feed lever lock pin



**SECTION-2**  
**INSTALLATION**

**2.1 Lifting the machine**

While lifting the machine by crane, proper care should be taken to prevent damage of machine paints, components and levers. Use suitable wooden block or felt packing, whenever chances of damage to machine part due to contact of Rope or chain are possible. Suitable capacity ropes / chains should be used, while lifting the machine and it should be lift in balance position. For proper balancing of the machine, move bed and carriage at appropriate position and clamp on base.

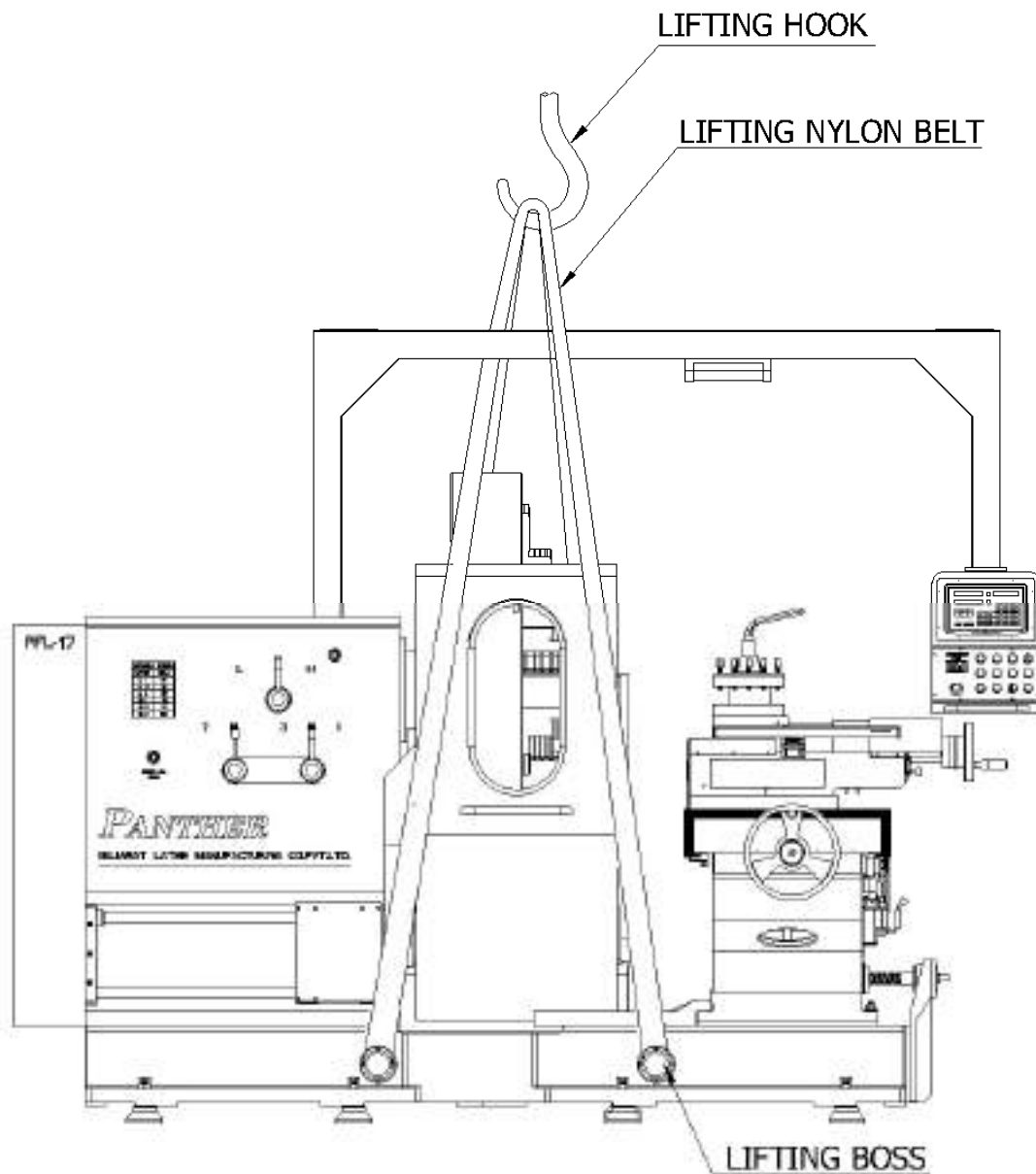



## **2.2 Unpacking and cleaning**

Once machine is brought in shop Floor, for unpacking of the machine, proper care should be taken. In case of machine with case packing, top direction is marked on wooden case. It is suggested that the packing case is opened soon after its receipt and verification is made for the standard and extra accessories mention in packing slip.

Prior to dispatch, all Slides all unpainted parts, handles etc. are coated with anti-corrosive / rust – preventive. This should be carefully removed and wiped dry and then all bright machine parts should be oiled immediately.

## **2.3 Foundation**

The lathe machine can give satisfactory performance only, if it is put on proper foundation and proper leveling is done. Foundation should be prepared as per foundation drawing and sufficient time should be allowed for concrete slab to be fully cured and dried. The depth of the foundation slab given in foundation drawing is only recommended and it should be directly decided by the users, depending upon the soil condition and surrounding atmosphere. The load bearing capacity of the soil should be taken in account for preparing foundation.

[Working Area: while selecting space and location for setting up the machine, leave enough space for convenient operation and easy accessibility of all parts for maintenance.]



Foundation Drawing:

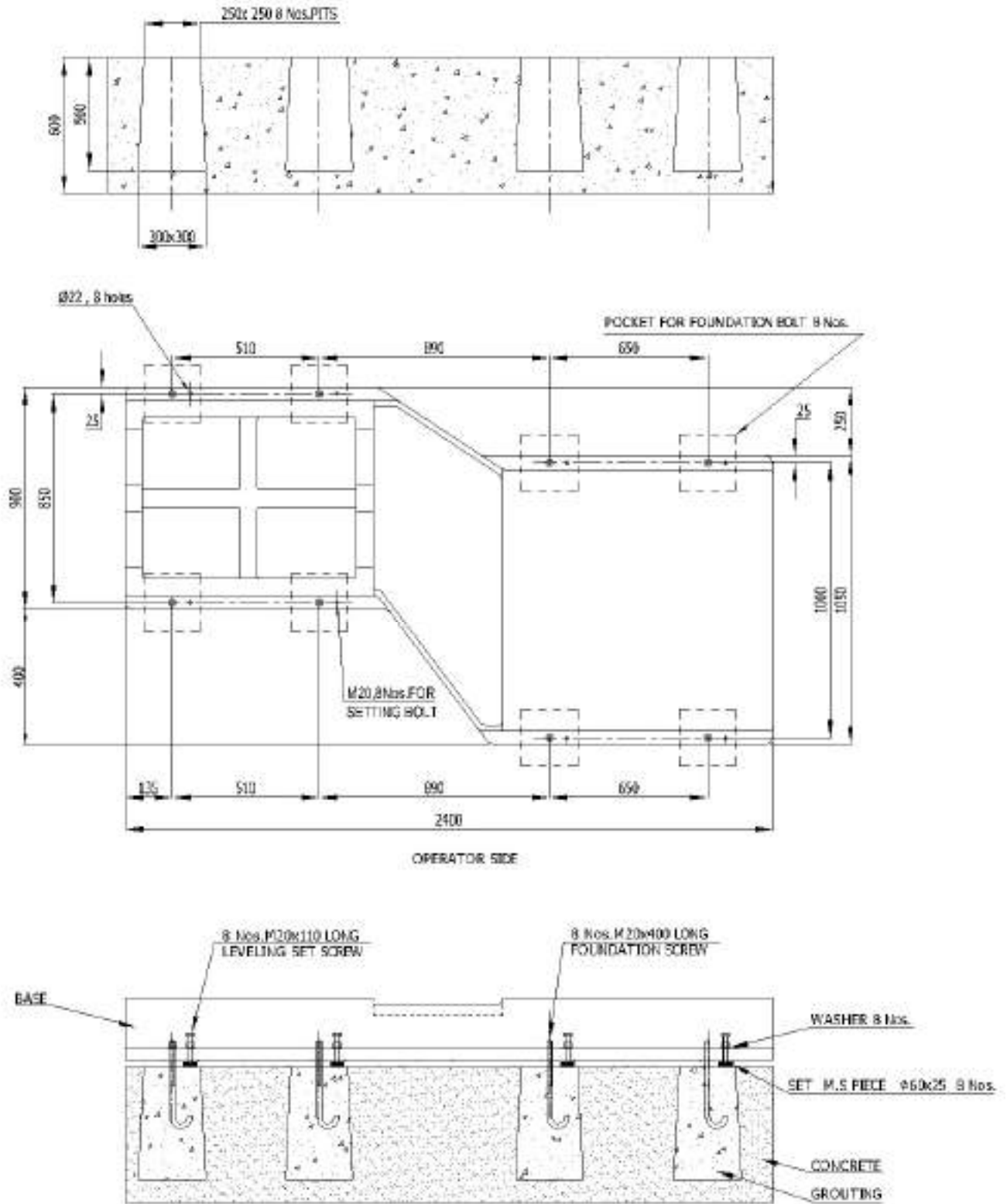

DRAWING FOR PITS OF FOUNDATION FOR FACING LATHE





## **2.4 Leveling**

Leveling should be carried out with proper care. The spirit level should be accurate. For leveling follow the procedure given below.

- Keep the precision spirit level on cross slide top face at Centre in transverse position.
- Adjust the leveling bolt to make the position of level bubble in Centre.
- Move carriage slide without disturbing level towards head stock side and adjust the bubble in level at Centre position by adjusting level bolt.
- Move carriage slide toward base side and repeat the procedure.
- Make both the readings at head stock side and carriage side to be identical
- After setting transverse level, move the carriage to the Centre of bed.
- Keep precision level on surface slide top near V-guide ways of bed in longitudinal position
- Ensure the bubble position at Centre of level by using thin paper if required
- Move bed towards head stock slide and then base side and ensure the variation and adjust level if required.
- Re-check the transverse level.

After proper leveling of machine, run the machine for about 2 hours at various speed and feed and recheck level and reset the level if required.

Then the foundation bolts are grouted in larger holes with 1:3 cement and sand mixture. Sufficient time should be allowed for concrete to cure. The foundation bolts are then tightened without undue force. Periodically checkup bed level to ensure continued level accuracy.



## Electric diagram

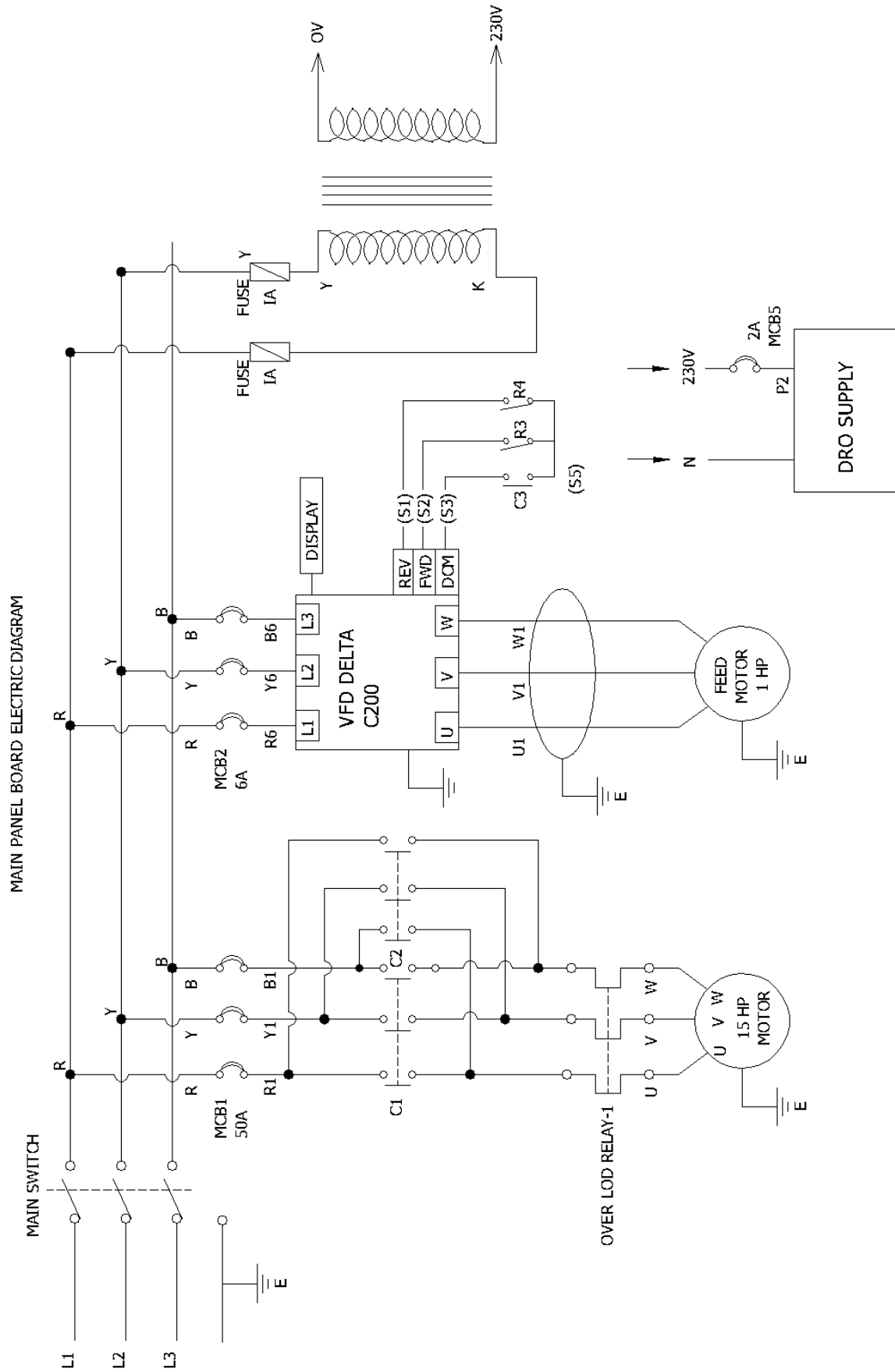



Electric diagram for push-button:

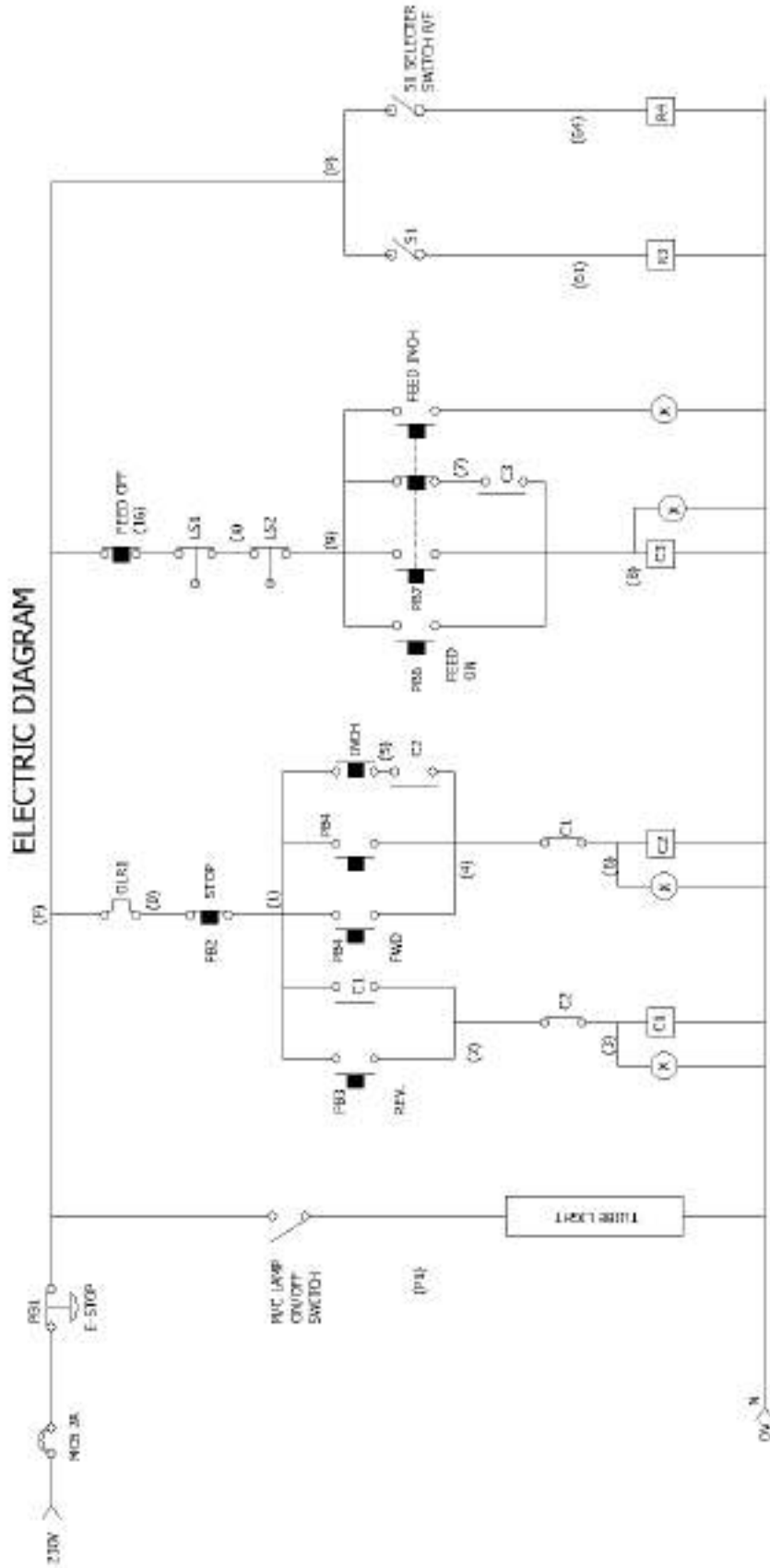

**2.6 Electric connection:**

Machine is supplied with electrical, hence internal wiring for electric motor and reverse/forward switch is done in machine. Connect Elect. Power supply of three phases with proper Ear-thing to machine. Please check for any leak aging of power supply for safety. Press ON push button to start power supply. Please check machine spindle rotation, if it is reverse direction it should be matched with position of rev / for start handle. If position is not matched than interchange any two pair of leads from main elect. Supply. During connection of power, main power supply should be kept off.

To stop the machine press OFF push button on rotate rev for handle in centre position. If machines stopped by OFF push button, for restart machine ON push button should be used..

Internal electric wiring of electric motor and controls is done with wiring panel kept in electric cabinet. Wiring diagram is also given in this manual. During connection of power, main power supply should be kept off.

**2.7 Idle Running of the machine:**

At the time of machine dispatch, speed and feed levers are set for the lowest value. You are requested to ensure that these positions are maintained at the time of starting the machine to avoid any accidental switching on at high speed and feed, which may damage the machine.

Machine saddle, tail stock spindle etc are kept locked at the time of machine dispatch. Do not try to move them until they are properly cleaned. Lubricated and unlocked.



• **2.8 Lubrications points:-**

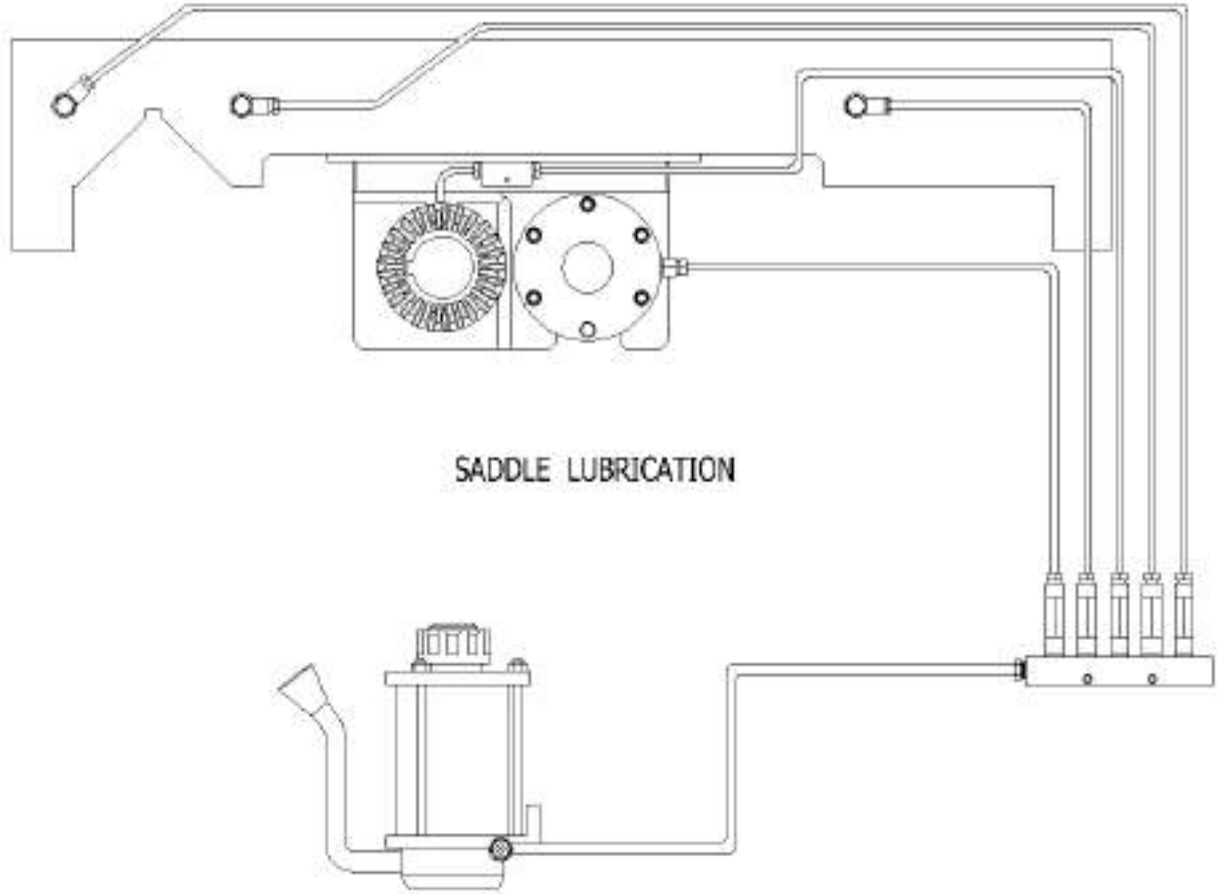



- Lubrifications points

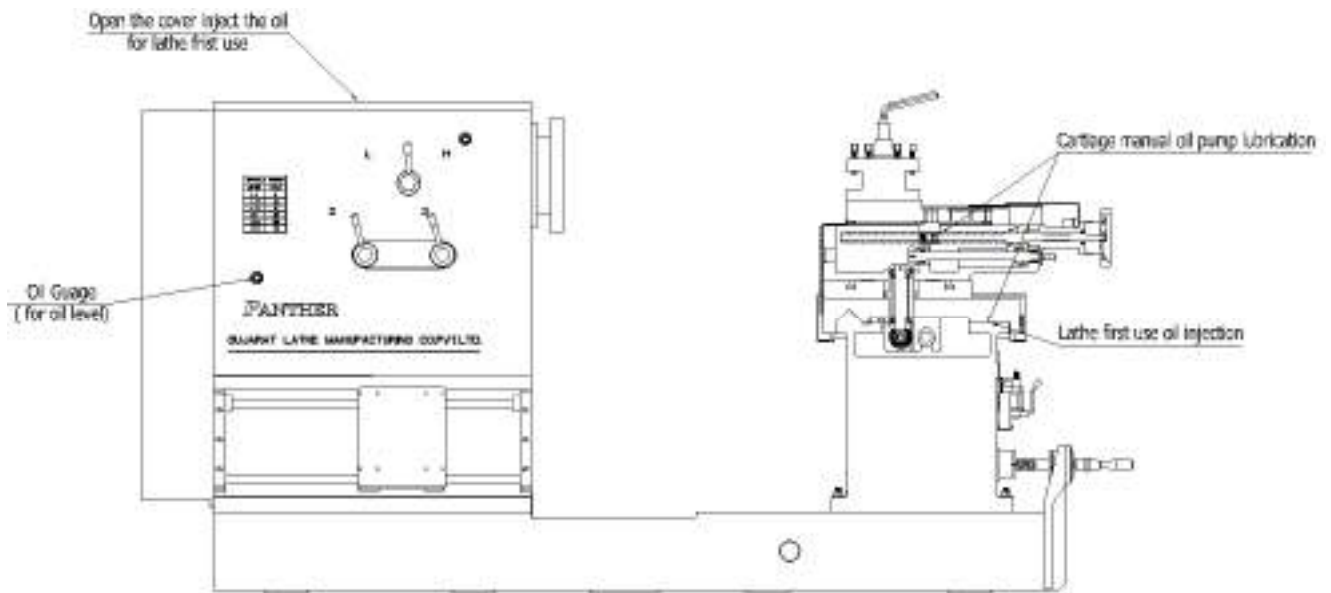

**2.9 Lubrication :**

Proper lubrication of lathe machine plays vital role to retain accuracy and gives satisfactory service. If lubrication is neglected the bearing surface may be damage, impairing the accuracy and shortening the life of machine.

Lubrication head stock and feed gear box are done by splash lubrication. Oil level indicator is provided in head stock and feed gear box. Check oil level through oil level indicator regularly, if oil level seems down then pour oil through oil filling plug. One gear pump is provided in the head stock for lubrication of head stock gears and bearings. Working of lubrication pump is indicated through oil window given in head stock front side.

In initial period, or first time running oil should be changed after first 300 hours running and then after 500 running hours.

Latter on oil can be used up to 1000 to 1500 running hours. Before filling new oil, the head stock should be washed with kerosene and thoroughly dried. Quantity of oil and type of oil to be used in head stock and feed gear box is show in lubrication chart. Lubrication of compound, surface slide and lead screw done by oil can. Various oil holes are provided for lubrication.

All the oil holes, oil cups, grease nipple of the lathe machine should be inspected and filled at least once in day or more often if machine is operate day and night shifts or high speed and feed value is engaged. Dirt chip should be brushed away before oiling or greasing to prevent them to enter in to holes.



**2.9.1 Lubrication through various oil holes:-**

Oil holes are provided at various places for oiling.

- (1) Lead screw boss & Hand-wheel
  - (2) Compound base & compound slide hand-wheel
- Apply oil daily in these oil holes by oil can.

**2.9.2 Lubrication through oil hand pump:-**

Various oil banjos are provided for oiling.

- (1) Saddle
  - (2) Bed guide ways
  - (3) Lead screw nut housing
- Apply oil daily in these oil holes by oil hand pump



**2.9.4 List of recommended lubrication regular checks:-**

Sr.. no.	Check area		Maintenance items	period
1	Lubricating system	Lubricating device pipeline	Clean the oil filter Check whether the pipeline leakage, plugging or rupture	1 year 6 months
2	Main spindle motor	Noise, vibration, temperature rise, Insulation resistance	Check the bearings and other parts if there is any abnormal sound ,vibration and temperature abnormal rise Measuring insulation resistance value normal or not	1 month 6 months
3	Carriage permanent feed gear box motor	Noise ,vibration, Temperature rise	Check the bearing and other parts if there is any abnormal sound ,vibration and temperature abnormal rise	1 month
4	Motor	Noise ,temperature rise	Check the bearing and other parts if there is any abnormal sound ,vibration and temperature abnormal rise	1 month
5	Operation panel	Electrical equipment and wiring terminals	Check the electrical device ,if there is any abnormal of odor, color, whether the tightness connection surface wear and connecting screws loose	6 months
6	Inner connection	Electrical connections between control box and lathe	Check and tighten the relay terminal screw Check and screw fastening relay terminals	6 months
7	Electric device	Sensor, solenoid valve, limit switch	Through the concrete operation to check its function and action status. Check and re-tighten the mounting screws and screw terminal blocks	1 month 6 months



8	Foundation	Lathe bed level	Level check and adjust the level	1 year
9	The X & Y axis motor	Sound vibrations and temperature rise	Check the bearing and other parts if there is any abnormal sound ,vibration and temperature abnormal rise	1 month
10	Face plate	Jaws	Removing of the face plate and cleaning the scissile chips	1 month
11	The X and Y axes	Clearance	Measure the gap by a dial indicator	6 months



**SECTION-3**

**OPERATION**

**3.1 Safety:**

- (01) Protect your eyes wearing safety glasses.
- (02) Wear shoes with oil resistance soles.
- (03) If you have long hair, tie it back properly.
- (04) Do not wear long sleeved cloths or loose clothing.
- (05) Make sure that your work area should be free from chips, coolant, electric wire, air-hoses, oil or anything that can be get in your way and cause you to fall.
- (06) Make sure that work holding are firm.
- (07) Make sure that tool holding are firm.
- (08) Ensure proper belt tension.
- (09) Re-fit covers and guards before the machine is put again into operation after opening of any cover or guards.
- (10) Do not file work piece, when they are being rotate under power. This is extremely hazardous.
- (11) Do not touch machine part immediately after machining it may have sharp edges and considerable amount of heat.
- (12) Wear rubber sole shoes while working on electrical cabinet.
- (13) All maintenance work should be done with power off condition.
- (14) Electrical shock can cause serious injury or loss of life. All service and maintenance work within the electrical cabinet should be performed by qualified electricians in power off condition.
- (15) When re-placing fuse always re-place them with the same type and rating. Do not substitute fuses for higher current or different voltage.
- (16) While working on the machine parts like brake unit, transformer etc. it may be extremely hot. Take sufficient care when handling such parts.
- (17) Do not shift gear in running condition of head stock & Feed gear box.



### **3.2 Do, Do Not & Checks:-**

#### **Do:**

- Check and maintain oil level in head stock, & Feed gear box.
- The following table gives guideline for selection of maximum spindle speed.
- Clean machine at the end of every shift.

#### **Do Not:**

- Do not shift gears in motion.
- Do not open head stock covers or end feed gear covers while machine is running.
- Do not exceed speeds of chuck or face plate beyond the specified limit.
- Do not exceed more than 30 reversals of the motor switches per hour.
- Do not remove chucks from threaded spindle by rotation spindle in reversed direction.
- Do not operate spindle locking lever while machine spindle is rotating

#### **Checks:**

- Do not start the machine at high speed with heavy jobs.
- Sudden reversal of spindle at speed above 145 RPM is not recommended.
- It is recommended that cast iron chucks should not be run at surface speed more than 16 mtr./sec. Accordingly 1200 mm diameter face plate should not run at more than 115 RPM.



**3.3 Head Stock. :**

Head stock pulley is directly driven by electric motor through five V-belts. Power transmission inside the head stock to main spindle is through gear arrangement. Total 6 nos. different spindle speeds are available.

Main spindle RPM is selected by two levers, High/low speed changing lever and Speed changing lever. Lever have two different positions one is high speed position second is low speed range. Lever are two different levers each lever have 3 different positions. L.H. Lever have position 1, Neutral & 2, similarly R.H. lever have position 3, Neutral. Both the levers are interlocked with each other. L.H. lever will give selection of position 1 or 2 and R.H. lever will give selection of position 3.

First of all put both levers in neutral position than rotate any one lever to your required position 1-2 or 3. If anyone lever is set in engage position than automatically second lever will be locked in neutral position.

Oil sight glass is provided for checking oil level in head stock. Lubrication of main bearings, gears, shifters and shafts are done by splash lubrication system as well as gear oil pump. Gear oil pump will give lubrication oil at various points in head stock with force lubrication. One Indicator glass is provided in head stock which indicates working of gear pump. It is necessary to keep always proper oil level in head stock to give lubrication of head stock parts. Oil filling plug is given on top face of head stock cover and oil drain plug is given at back side of head stock bottom face.

**CAUTION: Do not shift gear while M/c is running.**

**3.3.1 RPM Chart:-**

**SPINDLE SPEED IN RPM**

<b>LEVER POSITION</b>	<b>1</b>	<b>3</b>	<b>2</b>
<b>L</b>	15	20	27
<b>H</b>	60	85	115



3.3.2 Feed range chart :

FEED RANGE	
FREQUENCY Hz	X & Y AXIS FEED mm/min.
5	6.000
10	12.000
15	19.000
20	26.000
25	33.000
30	39.000
35	41.000
40	52.000
45	59.000
50	66.000

Feed mm/rev. =  $\frac{\text{Feed mm/min.}}{\text{R.P.M}}$

**3.4 Feed gear box:-**

Feed gearbox is provides for selection of various feeds.

Oil drain plug is given for adding or removing oil from Feed gear box. Oil sight glass is given for checking oil level in Feed gear box. It is necessary to maintain proper oil level in Feed gear box. Lubrication of Feed gear box is done by splash lubrication system.

**CAUTION: DO NOT SHIFT GEAR WHILE MACHINE IS IN RUNNING.**

**3.5 Carriage:-**

Carriage slide is fitted on bed top face with one lock piece and setting wedge at rear side and two lock pieces on front side. On the top face of compound height piece fitted on carriage. Aluminum chip guards with felt are given at all four corners of carriage to prevent to enter dust and chips inside the sliding surface. Oil hand pumps on side face of. One lock bolt is provided on carriage surface to lock carriage movement if required.

Compound base is fitted on compound base height piece. On the front face of carriage one screw boss fitted to guide surface screw and nut. Surface screw and gear is fitted in carriage and surface screw gun metal nut is fitted on bottom face of surface slide. One hand wheel with micro ring is fitted on surface screw to give manual hand feed to surface slide. On the top face of surface slide one circular T-slot is given and angular marking of 180 degree (90 degree on either side.) is done to set compound slide at any desire angular position.

Compound slide assembly is located in center of surface slide and clamped with compound height piece through 4 nos. T-bolts. One 4 way tool post is fitted on top face of compound slide to hold tools.

**Least count of hand wheels:-**

Longitudinal movements by hand wheel = 0.050mm / div

Compound slide hand wheel = 0.050mm /div



## Section - 4

### Settings and Maintenance

Proper care and maintenance of the machine is important factor to increase life and reliability of machine performance. Following are the few important settings, which needed attention.

#### 4.1 Headstock:-

##### 4.1.1 Taper setting:-

Head stock is mounted on bed by six bolts. To set head stock alignment, first loose bolts slightly and then insert test mandrel of 300 mm length in spindle nose and align axis of taper mandrel with longitudinal movements and clamped bolts.

##### 4.1.2 Spindle setting:-

Main spindle runs in two taper roller bearings and one roller bearing. To adjust radial or axial clearance of spindle tightens check nuts so that the spindle can be rotate by hand with light drag.

##### 4.1.3 V-Belts setting:-

Main electric motor is mounted on motor mounting bracket on back side of lathe bed. Five nos. V Belts are fitted between motor pulley and head stock pulley. To adjust belt tension, un-clamps four bolts of elect. Motor and re adjust the position of motor on motor on motor mounting bracket and clamp bolts.

#### 4.2 Lead screw:-

Lead screw is coupled with out-put shaft of Feed gearbox by Law-Jaw coupling.



**4.3 Carriage:-**

Carriage is fitted on bed with one V guide and one flat Compound height piece Carriage is set on bed guide ways with four keeper blocks on operator side and one keeper plate with parallel wedge in rear side.

**4.4 Compound slide and Compound base:-**

Compound slide and compound base is scraped and matched in guide ways with one wedge, setting bolts are given to set slide wedge clearance.

**4.5 Tool post:-**

After long use the tool post clamping handle may extend beyond the convenient zone of clamping. To get back proper angle of tool post clamping handle face the bottom spacer of clamping lever by required amount.

**4.6 Trouble shooting and remedy:-**

<b>SR.</b>	<b>TROUBLE</b>	<b>CAUSE</b>	<b>REMEDY</b>
1	Machine vibrates while running.	(A) Improper leveling.	Level machine properly and tighten on foundation
		(B) Job not balanced.	Balance job by adding counter weight and reduce spindle speed and feed.
2	Machine vibrates while machining and chatter mark on job.	(A) Improper tension of belts.	Adjust V belt tension.
		(B) Excessive tool over hang.	Reduce over-hang of tool and clamp tool rigidly
		(C) Wrong tool.	Check proper tool material and tool geometry
		(D) Wrong cutting parameters.	Select proper speed, feed and depth of cut consider job material, tool material and job diameter
		(E) Improper tool center.	Adjust correct tool center
		(F) Work holding not rigid.	Check job holding
		(G) Clearances between carriage, surface, or comp. slides are not proper.	Adjust proper clearances between all wedges
		(H) Slender components machine without support.	Put proper support to job
		(I) Back plate of chuck is loose.	Check back plate of chuck
		(J) Pre loading of main spindle is not correct.	Adjust pre loading of spindle



<b>SR.</b>	<b>TROUBLE</b>	<b>CAUSE</b>	<b>REMEDY</b>
3	Spindle runs too tight or loose.	(A) Preloading of spindle is not proper.	Adjust check nuts given at rear end of head stock such that spindle should rotate by hand with light drag
4	Machine cuts taper on job.	(A) Alignment of head stock is not proper.	Align head stock axis with carriage movement
5	Machine is not able to take heavy cuts.	(A) Belt tension is not proper.	Adjust proper belt tension
6	Noise in head stock.	(A) Lubricant is not sufficient. (B) Gear damage. (C) Bearing damage.	Check oil lever and maintain proper oil level. Replace damage gear. Replace bearing.



**SECTION-5**  
**ASSEMBLY DRAWING AND SPARE PART LIST**





- **5.1 Inter lock plate lever**

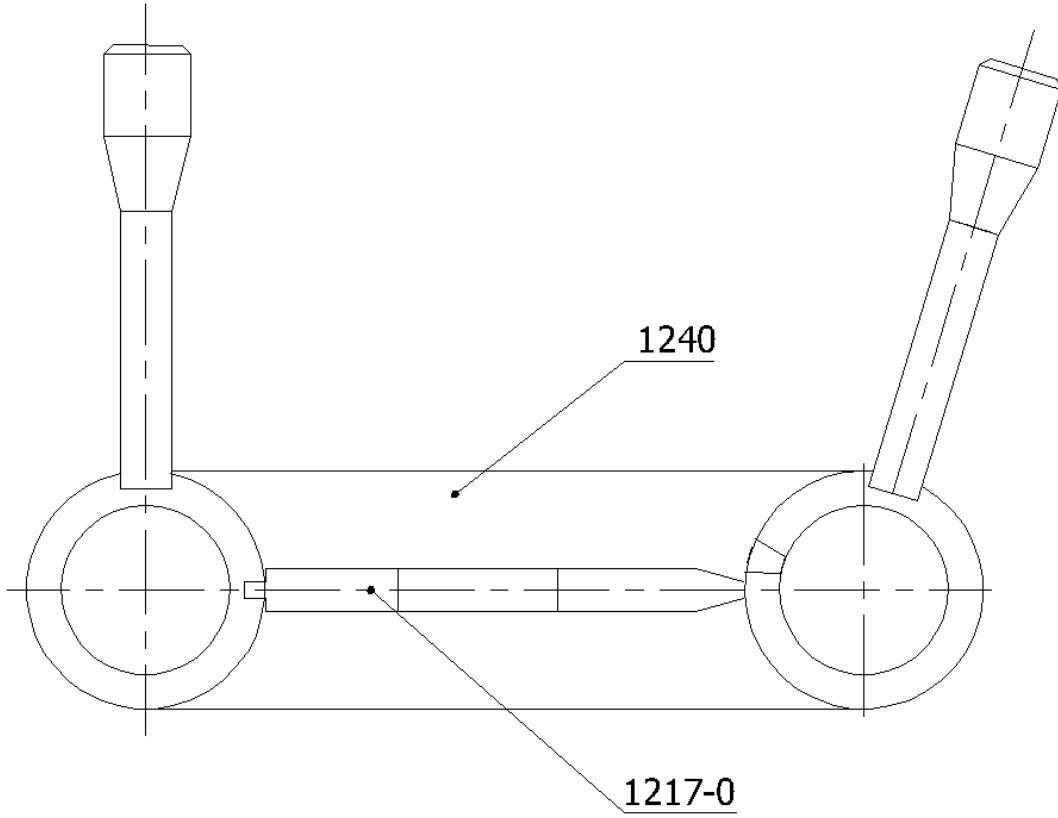



• 5.1 Head stock sub assembly :-

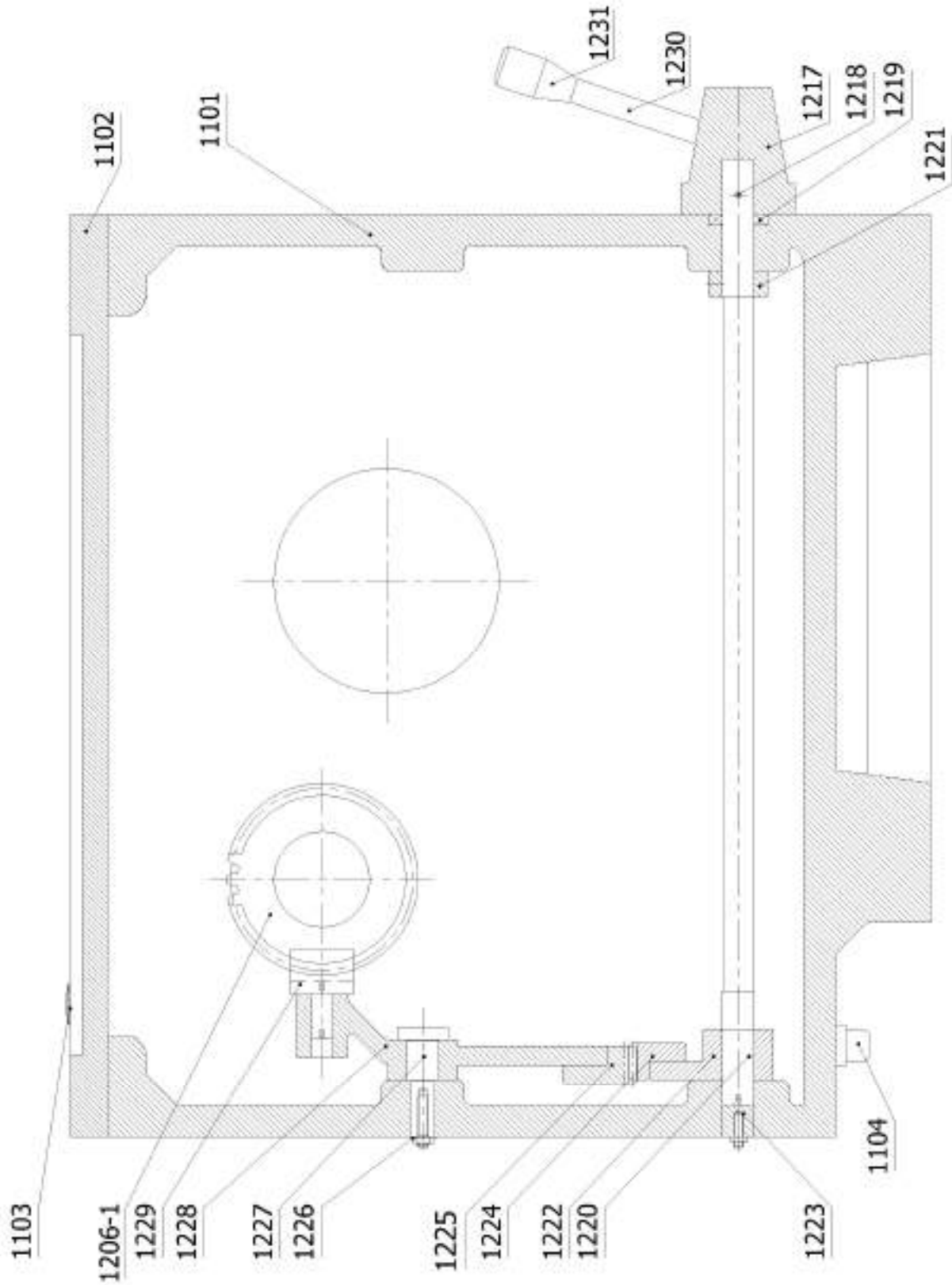



- 5.1 Head stock sub assembly

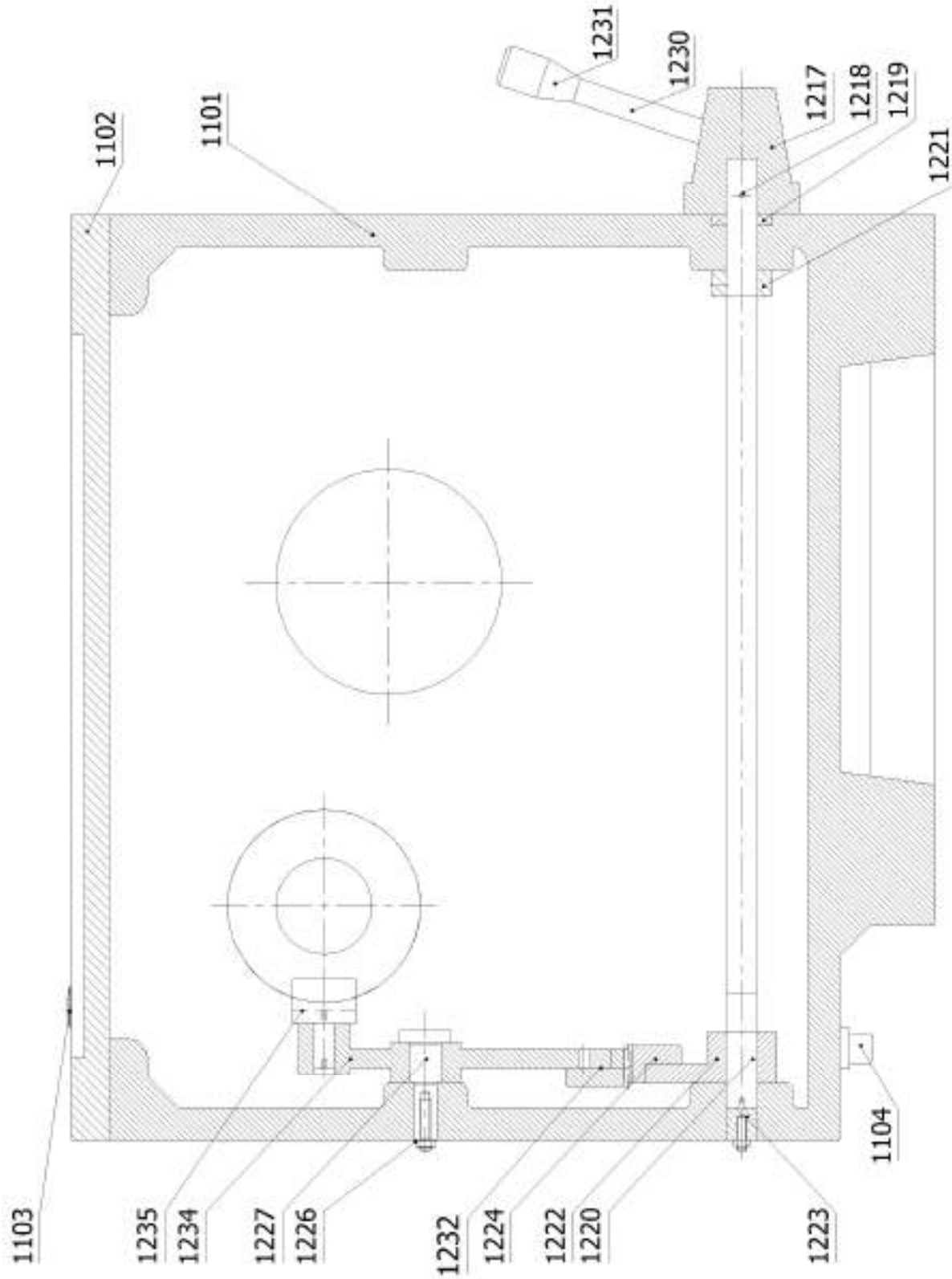





• 5.1 Head stock shaft assembly :-

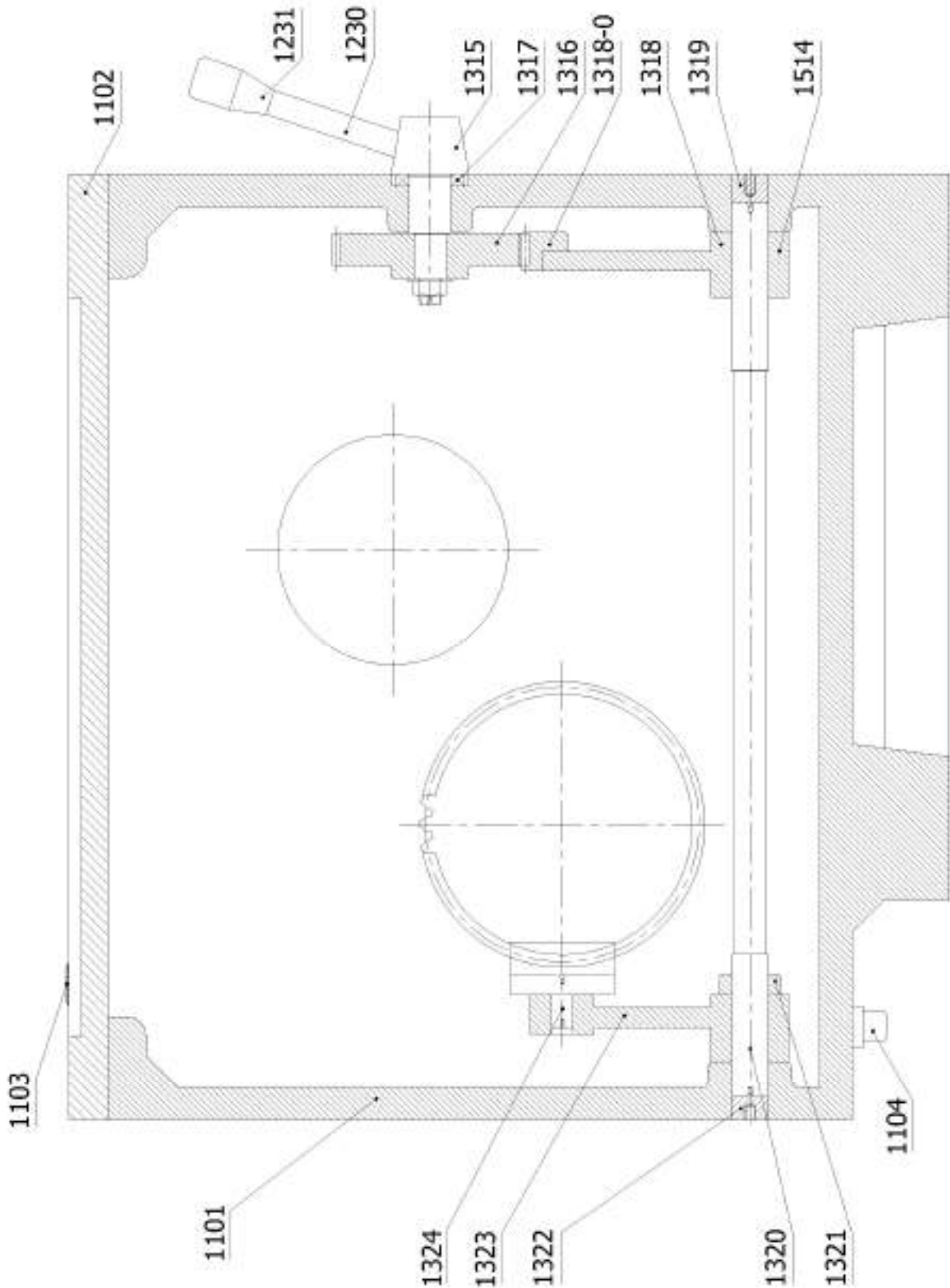

**5.1 Head stock assembly:-**

<b>Part No.</b>	<b>Part Name</b>	<b>Quantity</b>
1101	Head stock body	1
1102	Head sock top cover	1
1103	Oil filling plug	1
1104	Oil drain plug	1
1201	Driving shaft	1
1202	Plug	1
1203	G.M R.H Guide bush	1
1204	G.M. Middle guide bush	1
1205	G.M. L.H.guide bush	1
1206-0	Cluster gear Z = 16	1
1206-1	Cluster gear Z = 26	1
1207	Ball bearing ( No.6211 )	2
1208	Gear Z=21	2
1209	Gear shifter guide bush	1
1210	Oil seal 70-90-10	1
1211	Cover	1
1212	Head stock driving pulley	1
1213	Washer	1
1214	Driving pulley locknut	2
1215	Spacer	1
1216	Spacer	1
1217	Front lever boss	2
1217-0	Inter locking key	1
1218	Taper pin	2
1219	Oil seal 25-42-7	1
1220	Gear shifter shaft for gear (No.-1206	2
1221	Collar	2
1222	Bottom gear sector type lever	2
1223	Plug	2
1224	Gear sector for bottom lever	2
1225	Gear sector for top lever	1
1226	Washer	2
1227	Top lever locating pin	2
1228	Top lever for gear shifting	1
1229	Fork	1
1230	Handle for front lever boss	3



<b>Part No.</b>	<b>Part Name</b>	<b>Quantity</b>
1231	Knob	4
1232	Gear sector for top lever for gear(No.-1208)	1
1234	Top lever for gear shifting	1
1235	Fork	1
1236	Driving gear for pump Z=70	1
1237	Gear Z=56	1
1238	Locating plate	1
1239	Gear pump	1
1240	Inter locking plate	1
1301	Middle shaft	1
1302	End plug	1
1303	G. M. Guide bush L H side	1
1305	Gear Z = 63	1
1305-0	Collar	1
1306	Check nut for gear 1308	1
1307	G. M. Middle guide bush	1
1308	Gear Z = 68	1
1309	Gear Z = 44	1
1310	Gear Z = 16	1
1311	Gear Z = 58	1
1311-0	G.M.Bush	1
1312	Middle shaft and guide bush	1
1312-0	C.I .Bush	1
1312-1	Bush	1
1315	Front lever pin for gear 3010	1
1316	Gear Z = 40	1
1317	Oil seal	1
1318	Shifter lever for bottom shaft	1
1318-0	Gear sector for bottom lever	1
1319	Plug	1
1320	Gear shifter lever for bottom shaft	1
1321	Collar	1
1322	Plug	1
1323	Rear side gear sifter lever	1
1324	Fork	1
1325	Stopper	1
1601	Spindle bayonet size 11 type	1
1602	Lock ring	1



<b>Part No.</b>	<b>Part Name</b>	<b>Quantity</b>
1603	Front bearing cover	1
1604	Gear Z=79	1
1605	Gear Z=51	1
1607	Bearing spacer	1
1608	Inner spacer	1
1609	Tapper roller bearing(32232)	1
1610	Ball bearing(6232)	1
1611	Tapper roller bearing(32226)	1
1612	Spindle check nut	2
1613	Rear bearing spacer	1
1614	Rear bearing cover	1



• 5.2 Feed gear box assembly :-

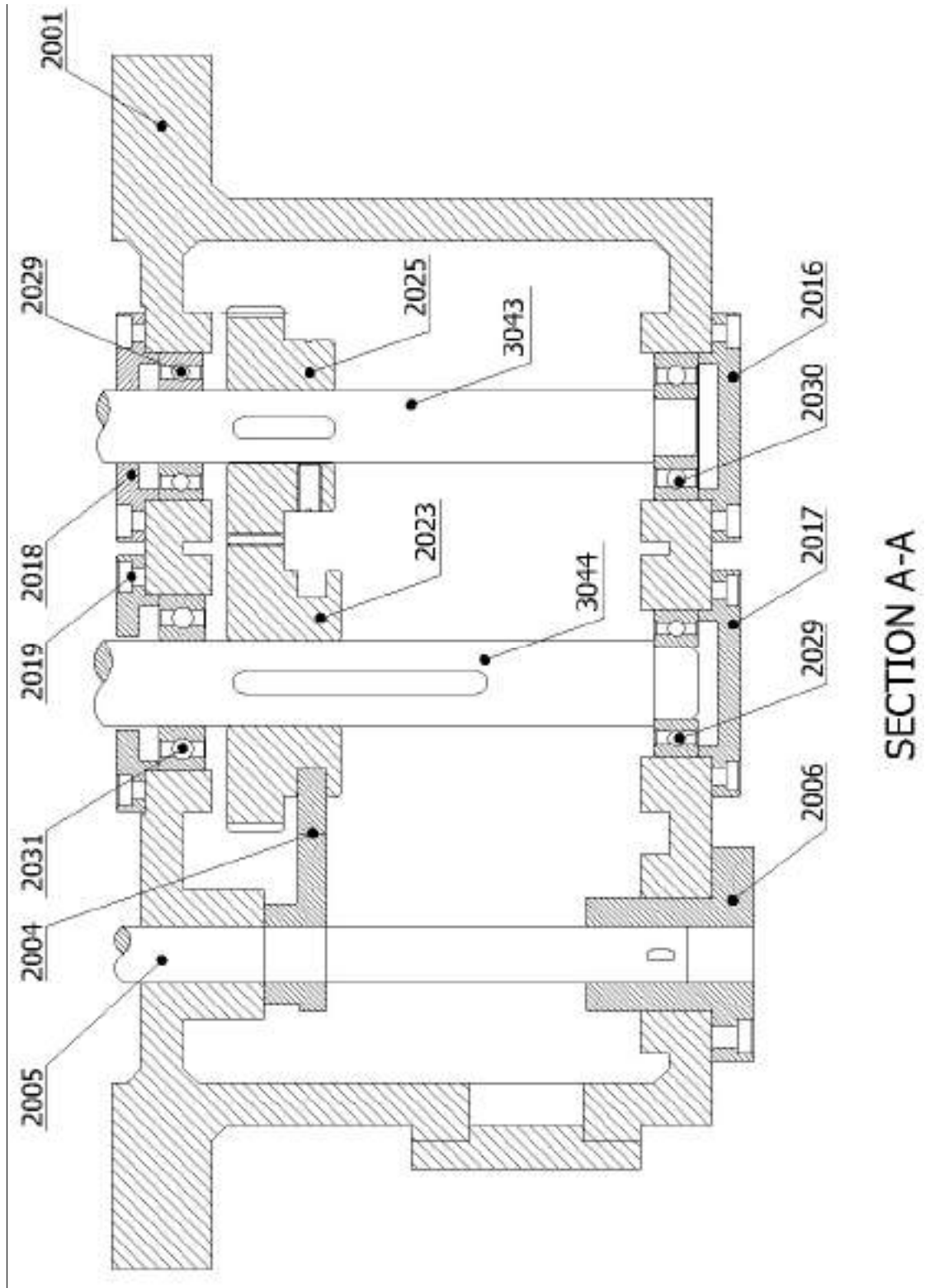



• 5.2 Feed gear box assembly :-

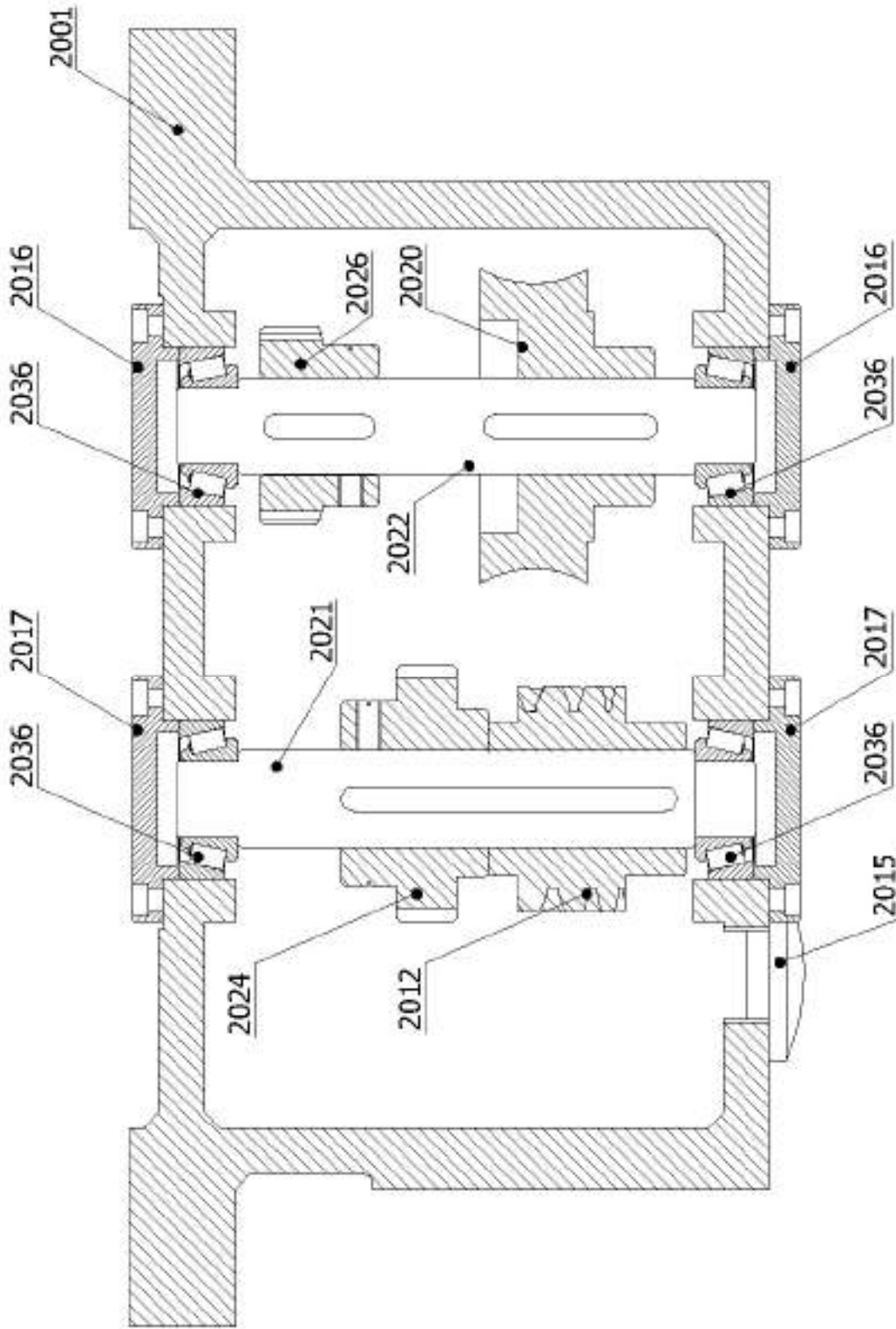

SECTION B-B



• 5.2 Feed gear box assembly :-

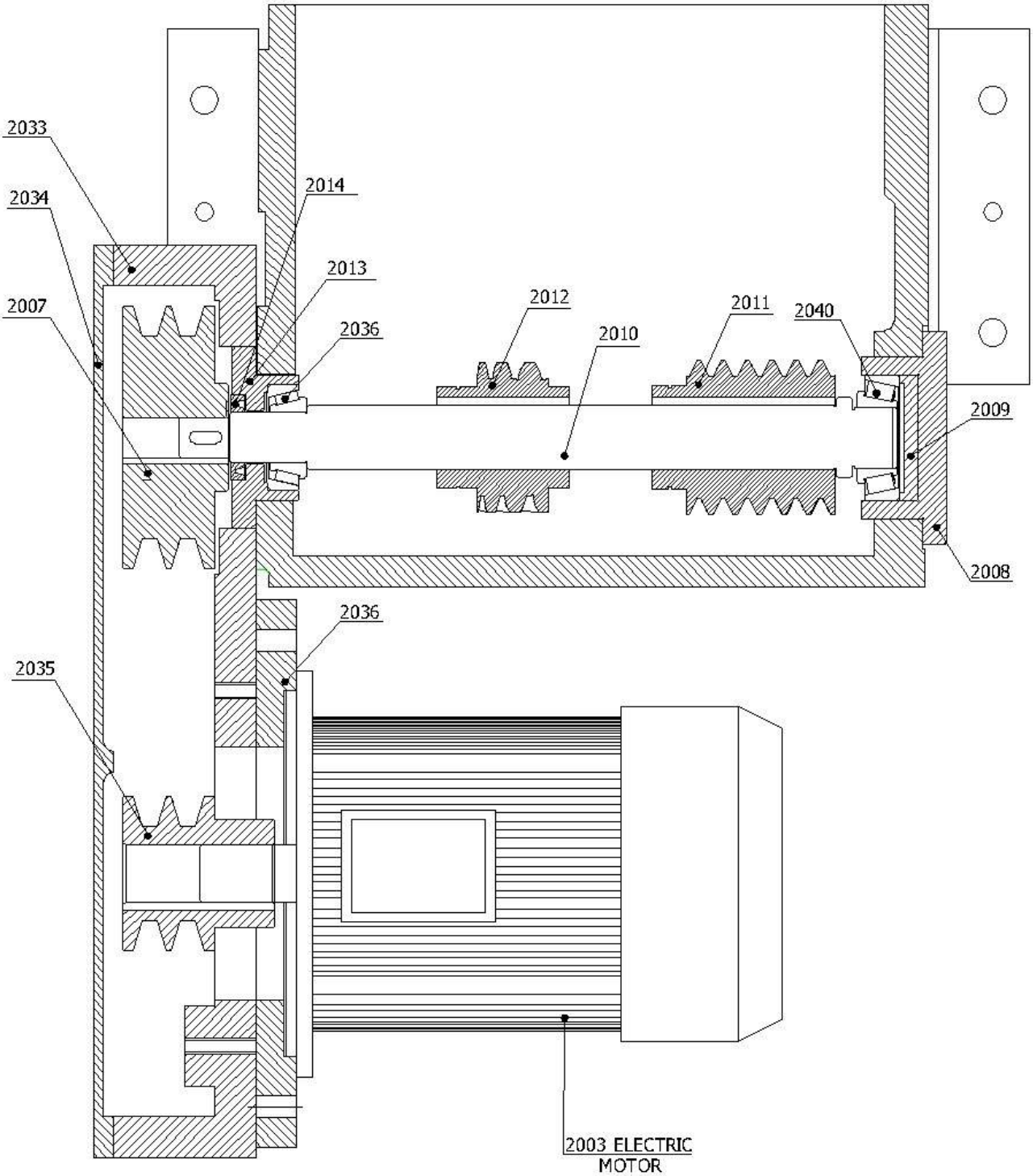

SECTION C-C

**5.2 Feed gear box assembly:-**

<b>Part No.</b>	<b>Part Name</b>	<b>Quantity</b>
2001	Feed gear box body	1
2002	Feed gear box body cover	1
2003	Electric Motor	1
2004	Shifter lever	1
2005	Rake Z=13	1
2006	Bush	1
2007	Feed box pulley	1
2008	Bearing housing	1
2009	Resting bush	1
2010	Warm for shaft	1
2011	Worm gear	1
2012	Helical gear Z=15	2
2013	warm shaft housing	1
2014	Oil seal 42x25x7	1
2015	Oil level check	1
2016	Ball bearing cover	3
2017	Ball bearing cover	3
2018	Bearing cover	1
2019	Bearing cover	1
2020	G.M Worm gear Z=29	1
2021	Shaft for helical	1
2022	Shaft for worm	1
2023	Spur gear Z=50	1
2024	Spur gear Z=40	1
2025	Spur gear Z=40	1
2026	Spur gear Z=30	1
2027	Knob	1
2028	Tapper roller bearing-32205	5
2029	Ball bearing -6205	2
2030	Ball bearing -6304	1
2031	Ball bearing -6206	1
2032	Tapper roller bearing -32206	1
2033	Belt housing body	1
2034	Belt housing cover	1
2035	Motor pulley	1
2036	Motor adjustment plate	1





• 5.3 Carriage , gears and tool post assembly :-

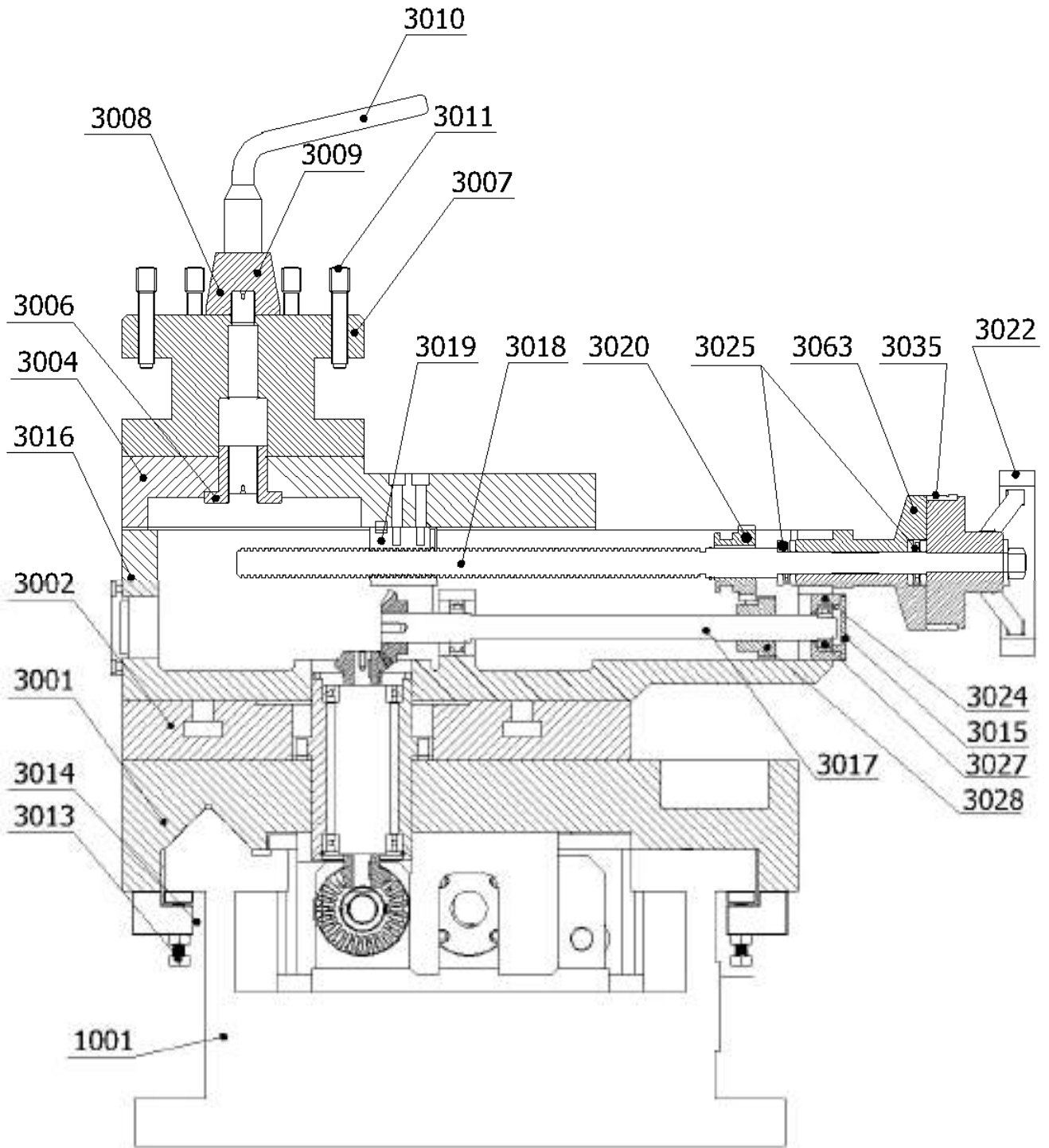



• 5.3 Carriage ,gears and tool post assembly :-

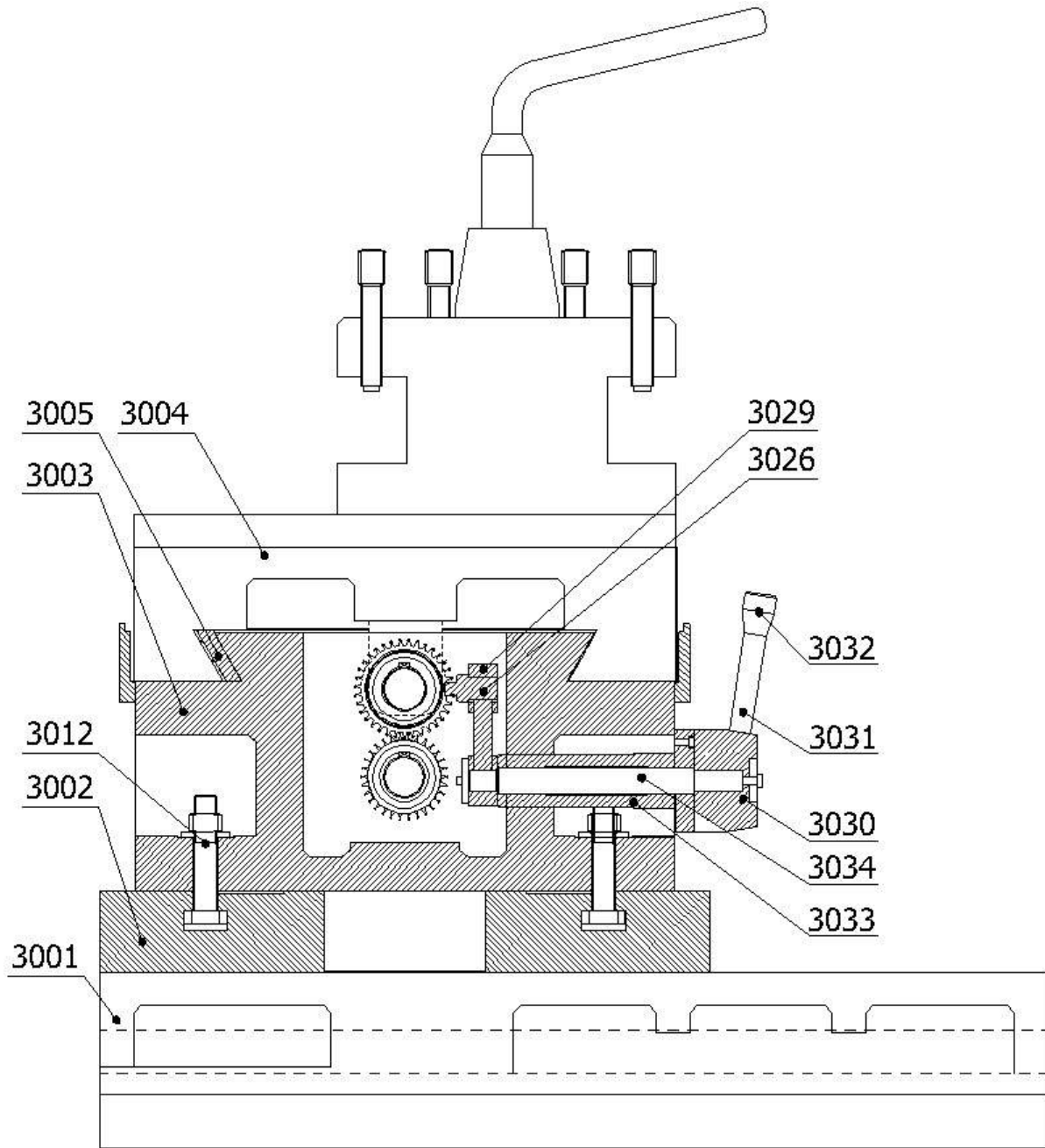



• 5.3 Bevel gear housing assembly :-

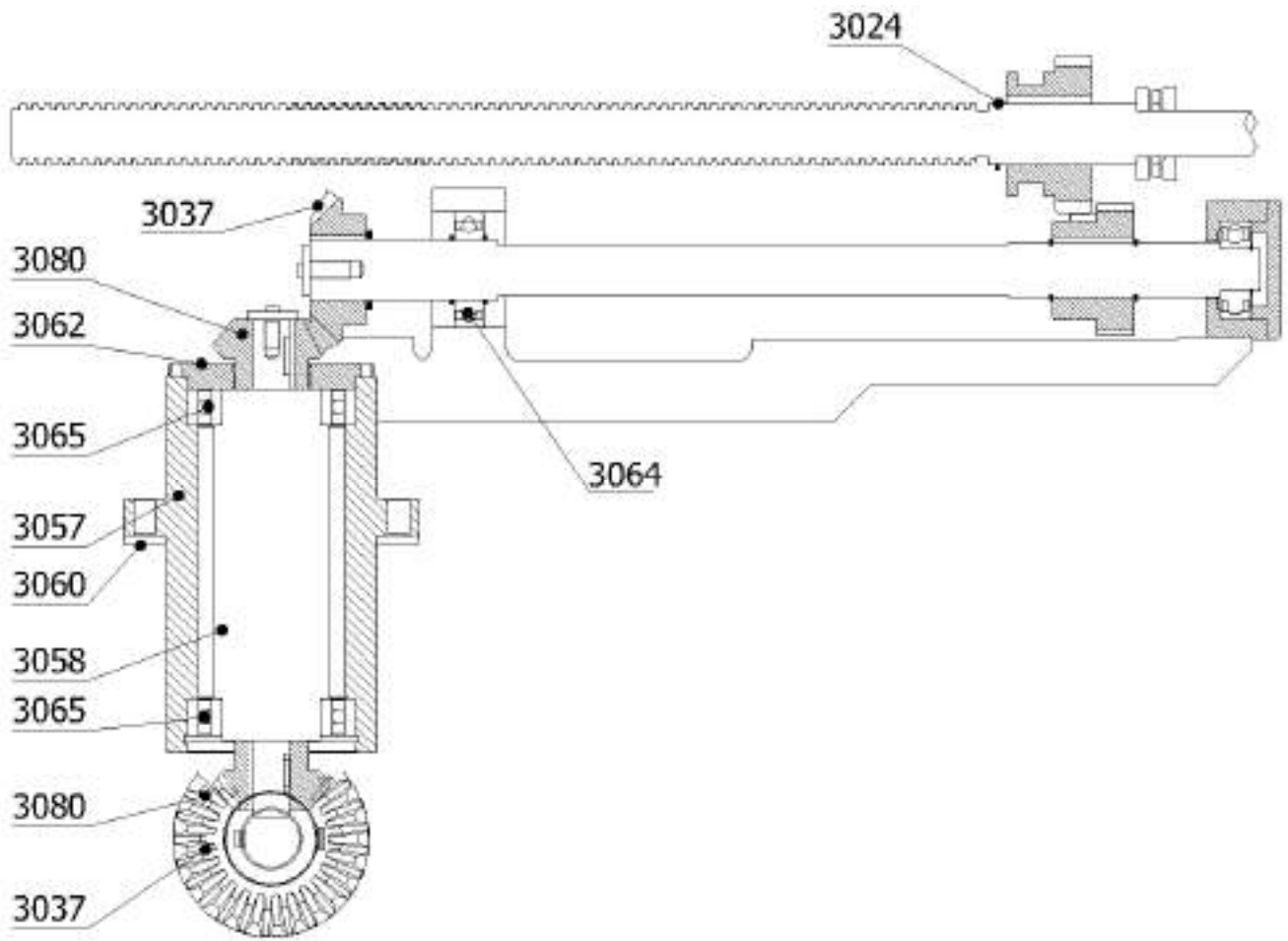



• 5.3 Bevel gear housing assembly :-

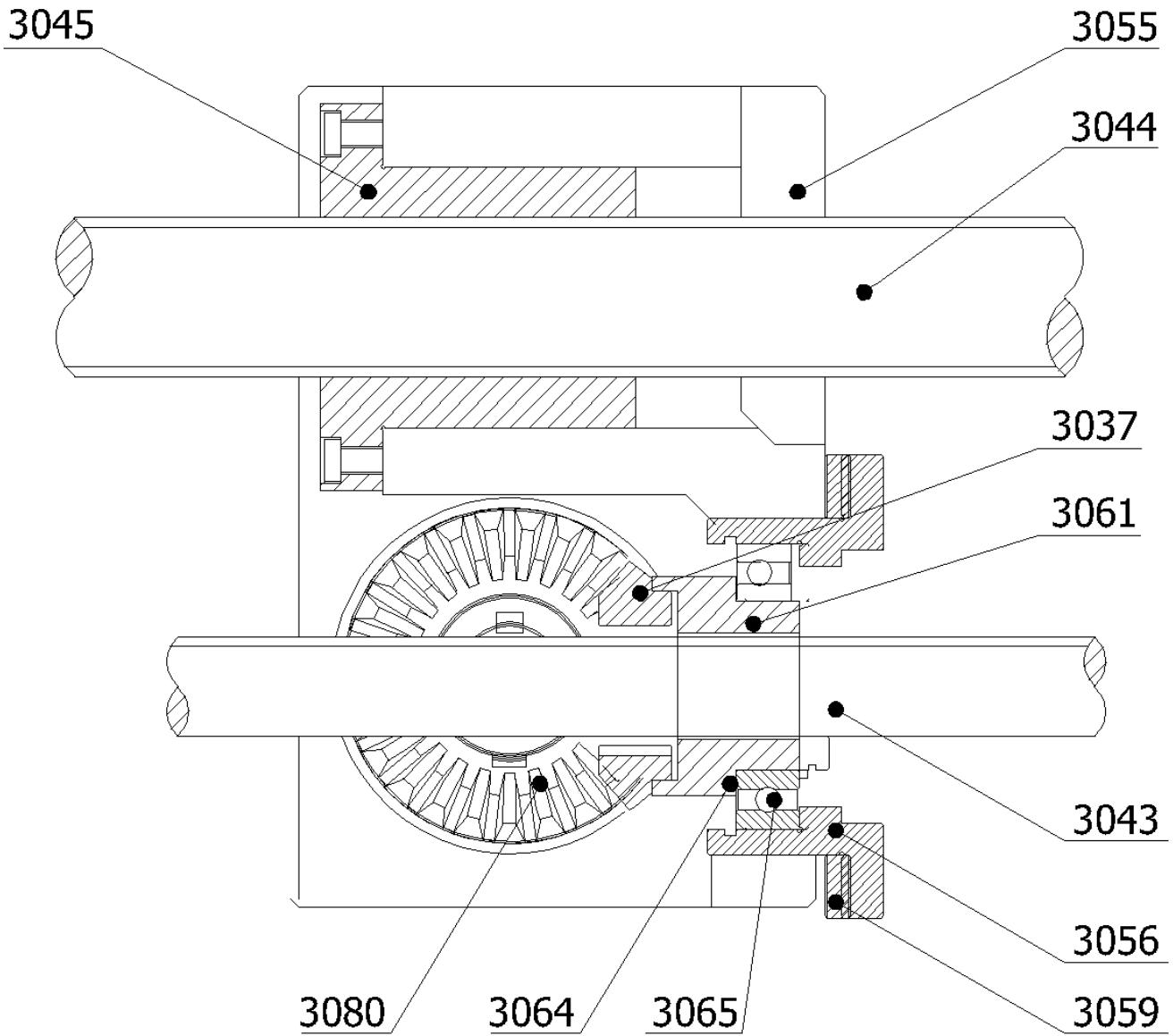



• 5.3 Carriage hand wheel :-

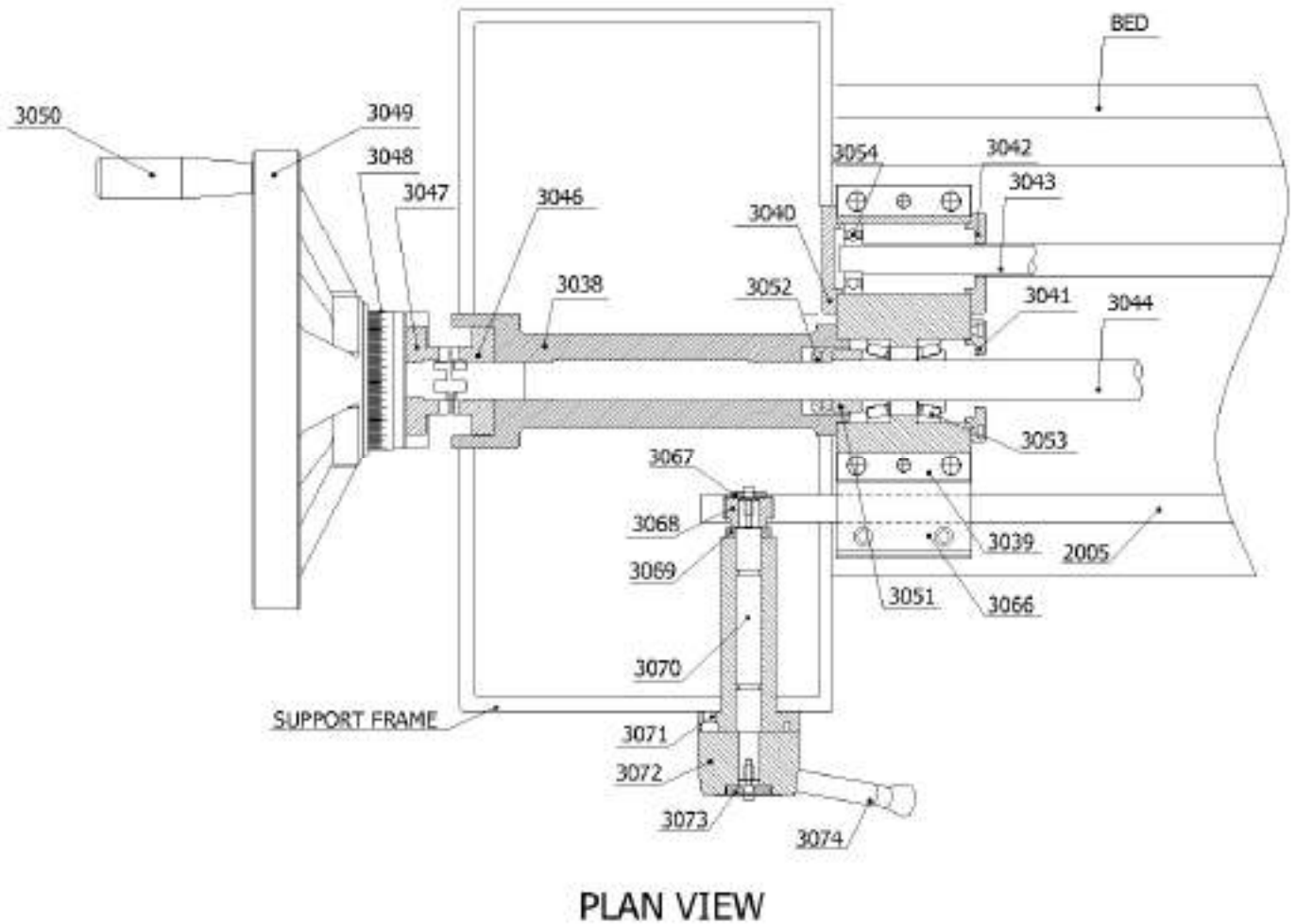

**5.3 Carriage, gears and tool post assembly:-**

<b>Part No.</b>	<b>Part Name</b>	<b>Quantity</b>
3001	Saddle	1
3002	Height piece for compound	1
3003	Compound base	1
3004	Compound slide	1
3005	Compound slide wedge	1
3006	Compound slide threaded bush	1
3007	Tool post	1
3008	Tool post stud	1
3009	Tool post clamping bolt	16
3010	Tool post handle	1
3011	Tool post clamping bolt	1
3012	T – bolt	4
3013	Keeper plate	4
3014	Keeper plate wedge	4
3015	Bearing cap	1
3016	Bearing cap	1
3017	Feed rod for compound	1
3018	Compound screw	1
3019	Screw nut G.M	1
3020	Gear Z= 35	1
3021	Compound boss	1
3022	Compound slide wheel	1
3023	Micro-ring	1
3024	Bearing housing	1
3025	Thrust bearing 08	2
3026	Ball bearing 6006ZZ	1
3027	Ball bearing 6203	1
3028	Gear Z = 30	1
3029	Shifter lever	1
3030	Feed reversing lever	1
3031	Stud	1
3032	Knob	1
3033	Bush	1
3034	Shifter lever pin	1
3035	Micro ring	1



<b>Part No.</b>	<b>Part Name</b>	<b>Quantity</b>
3036	Fork G.M	1
3037	Bevel gear Z= 22T	2
3038	Lead screw boss	1
3039	Lead screw pedestal	1
3040	Bearing cap	1
3041	Bearing cap	1
3042	Bearing cap	1
3043	Feed shaft	1
3044	Lead screw	1
3045	Lead screw nut G.M	1
3046	Claw bush female	1
3047	Claw bush male	1
3048	Micro-ring	1
3049	Hand wheel	1
3050	Plastic hand-wheel grip with stud	1
3051	Lead screw spacer	1
3052	Lead screw check nut-KM-6	2
3053	Tapper roller bearing 32206	2
3054	Ball bearing 6205	1
3055	Lead screw nut housing	1
3056	Bearing housing	1
3057	Bevel gear housing	1
3058	Bevel gear housing shaft	1
3059	Spacer	1
3060	Spacer	1
3061	Feed shaft housing	1
3062	Bevel gear housing cap	1
3063	Compound boss	1
3064	Bearing 6005	1
3065	Ball bearing 6008ZZ	3
3066	Support bush for rake	2



<b>Part No.</b>	<b>Part Name</b>	<b>Quantity</b>
3067	Washer	1
3068	Spur gear Z-17T	1
3069	Spacer	1
3070	Shifter lever pin	1
3071	Bush	1
3072	Lever	1
3073	Washer	1
3074	Lever handle	1
3075	Bevel gear Z-15T	2





5.4 Safety door assembly:-

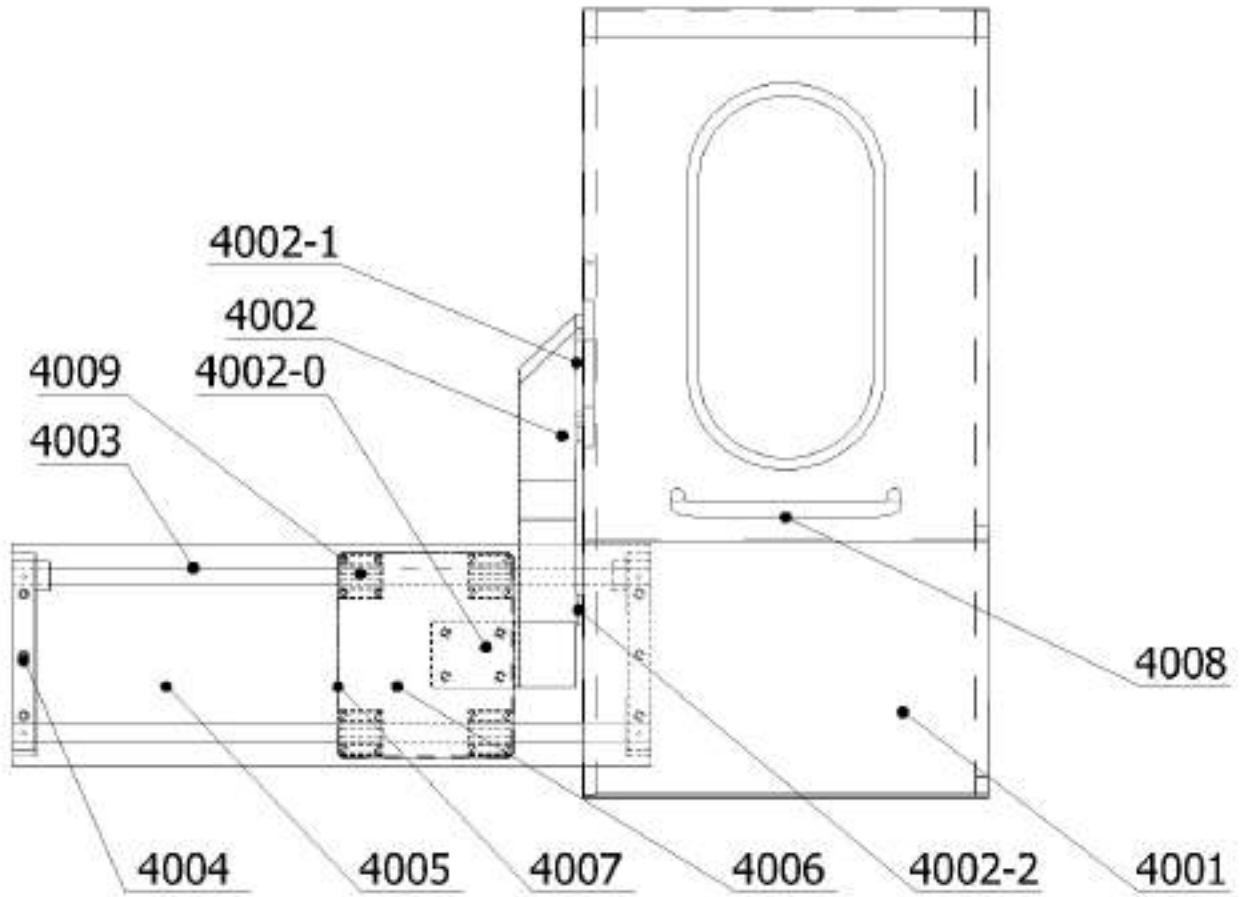

**5.4 Safety door assembly:-**

<b>Part No.</b>	<b>Part Name</b>	<b>Quantity</b>
4001	Safety door	1
4002	Door bracket	1
4002-0	Door bracket plate	1
4002-1	Door bracket plate	1
4002-2	Door bracket washer	1
4003	Standard lm shaft Ø30x110	2
4004	Shaft support	2
4005	M.S.sheet	1
4006	M.S. plate	1
4007	Bracket cover	1
4008	Door handle	1
4009	LM case unit sc30UU	4



5.5 Bed setting alignment sub assembly:-

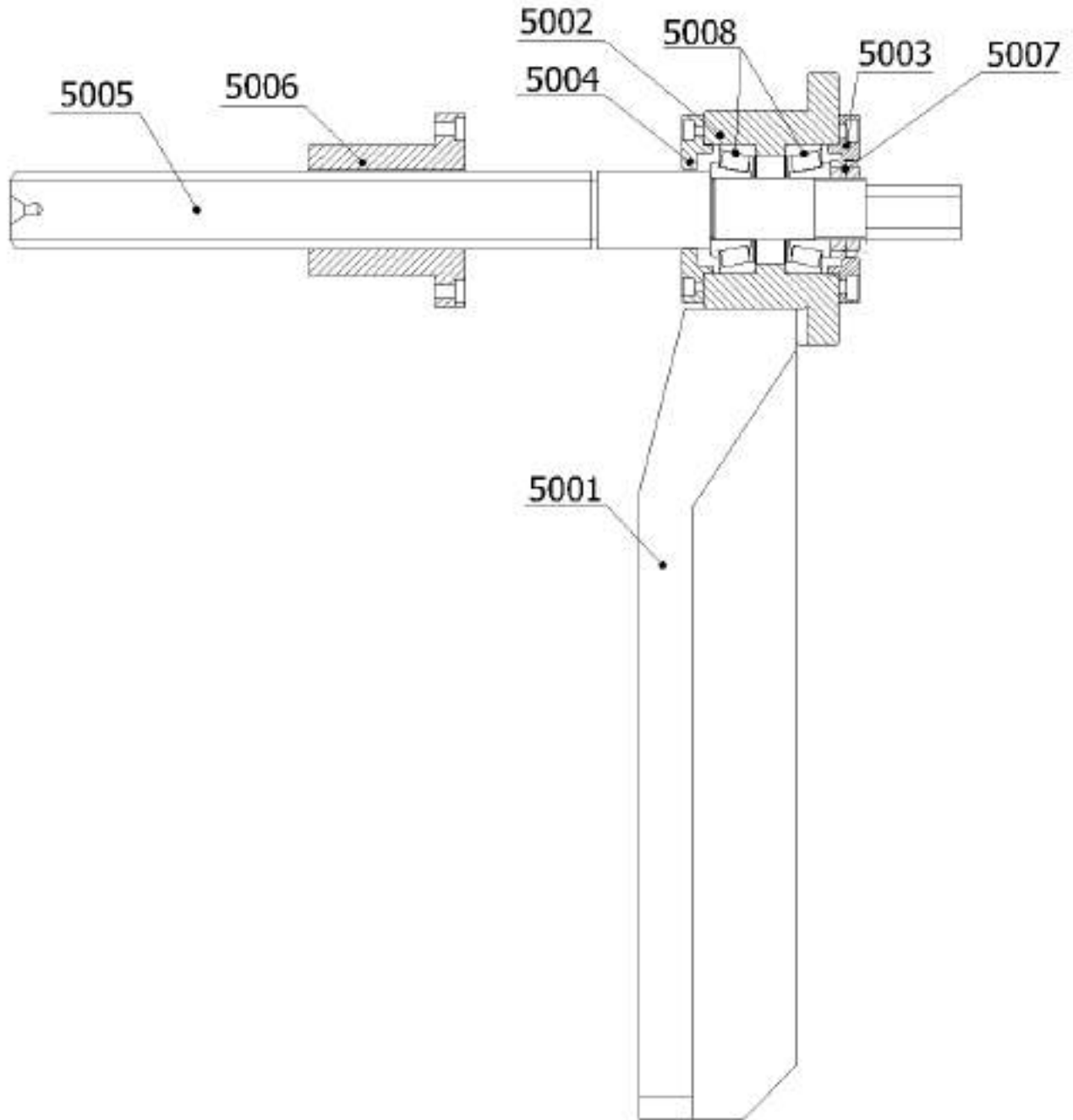



**5.5 Bed setting alignment sub assembly:-**

<b>Part No.</b>	<b>Part Name</b>	<b>Quantity</b>
5001	Bed setting bracket	1
5002	Bearing housing	1
5003	Bearing cap	1
5004	Bearing cap	1
5005	Screw	1
5006	G.M. screw nut	1
5007	Screw check nut	2
5008	Tapper roller bearing-32205	2



5.6 Hanging panel subassembly:-

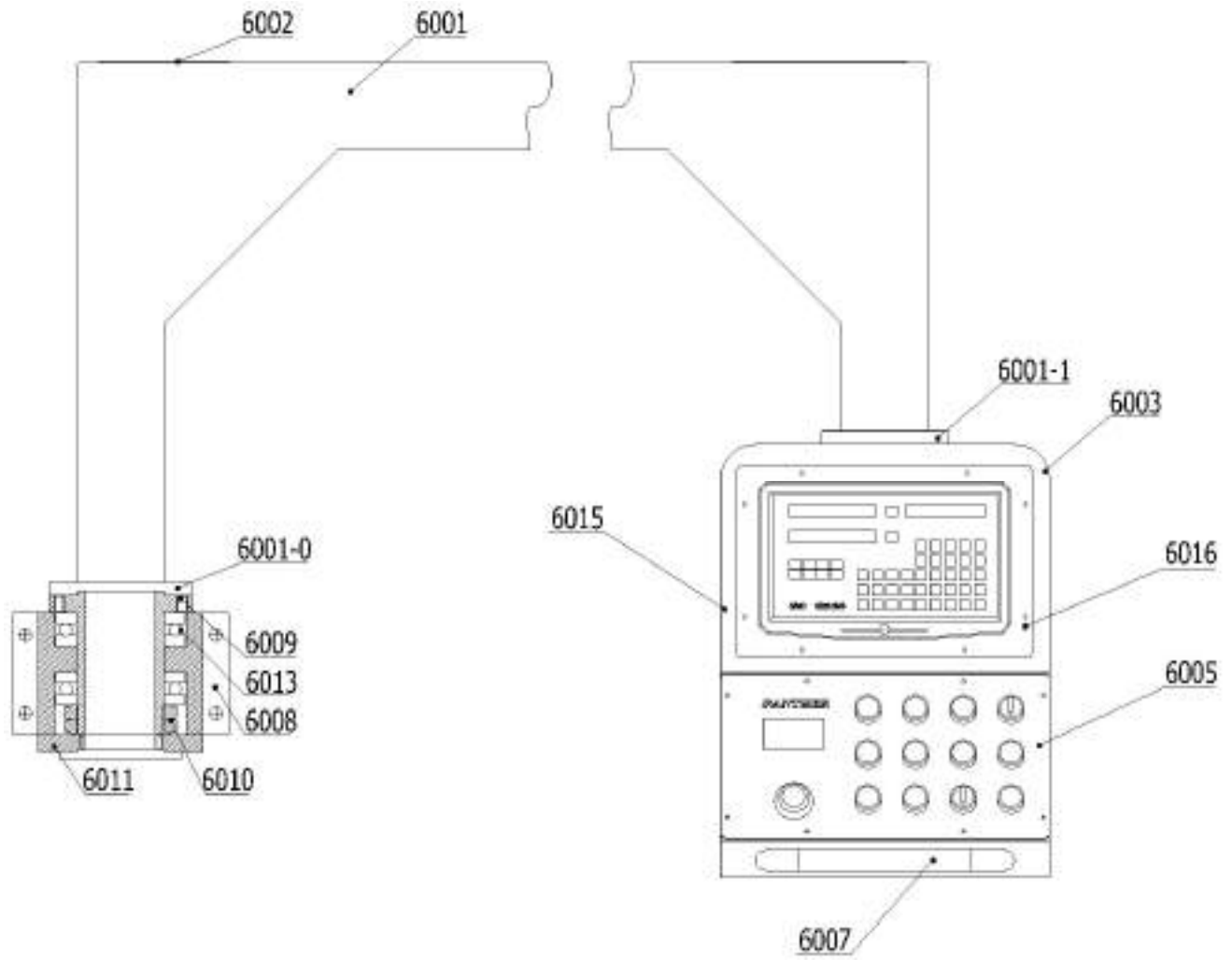

**5.6 Hanging panel subassembly:-**

<b>Part No.</b>	<b>Part Name</b>	<b>Quantity</b>
6001	Hanging panel frame	1
6001-0	Back plate pedestal side	1
6001-1	Back plate co. Panel side	1
6002	Arm top cover	2
6003	Control panel	1
6004	Control panel cover	1
6005	Push button sheet	1
6006	Control panel resting plate	1
6007	Control panel handle LH	1
6008	Thrust bearing pedestal	1
6009	Thrust bearing housing	1
6010	Check nut	2
6011	Pedestal cap	1
6012	Panel resting cap	1
6013	Thrust bearing 51220	2
6014	DRO monitor support	1
6015	Control panel support	1
6016	DRO sheet	1



**Test chart**

SR.	FIGURE	OBJECTS	PERMISSIBLE DEVIATIONS	ACTUAL ERROR
1		Straightness of carriage slide ways (a) In longitudinal direction (b) In transverse direction.	0.050mm (Convex) 0.040 mm	
2		(a) Periodic axial slip (b) Coming of the face plate mounting surface	(a) 0.015mm  (b) 0.020mm (Including periodic axial slip)	N.A
3		Run out or spindle nose	0.015 mm	
4		True running of taper bore of spindle (a) Near to the spindle (b) At a list. 300 mm	0.015 mm 0.050 mm	
5		Parallelism of the longitudinal movement of the tool slide to the spindle axis	0.040 mm upwards only	
6		Squareness of the transverse movement of the cross slide to spindle axis	0.020 mm	0.010mm As Per Practical Test No:-2





**Practical test**

SR.	FIGURE	OBJECTS	PERMISSIBLE DEVIATIONS	ACTUAL ERROR
1		Turning of cylindrical test piece held in chuck (a) Roundness (b) Cylindricity	(a) 0.020 mm (b) 0.040 mm	
2		Facing of cylindrical test piece held in chuck (Flat or Concave only.)	0.025 mm dia.	
4		Hardness of lathe bed (a) Standard bed (b) Flame harden bed	180 BHN min. 300 BHN min.	--

- **THE MACHINE CONFIRMS TO GRADE – 1 STANDARD OF ACCURACY AS PRESCRIBED BY D.O. (TOOLS).**
- **THE TEST CHART USED IS TO IS : 1878 (PART – 1) – 1971.**

- INSPECTION DEPT : \_\_\_\_\_.

**For, Gujarat Lathe Mfg. Co. Pvt. Ltd.  
Shapar (Dist. Rajkot)**